

STOVAX

Fire Your Imagination

Studio

Built-In Convector



Instructions for Use, Installation & Servicing

For use in AU (Australia)

These products are tested in accordance with AS/NZS 4012:2014, AS/NZS 4013:2014 and AS/NZS 2918:2001 and comply with emission requirements for Australia when using Hardwood.

For New Zealand

All installations must be carried out by an S.F.A.I.T (Solid Fuel Authorised Technician).

The Studio must be bolted through to the hebel or base to comply with the seismic restraint provisions of AS/NZS 2918:2001

IMPORTANT

THE OUTER CASING, FRONT AND GLASS PANEL BECOME EXTREMELY HOT DURING OPERATION AND WILL RESULT IN SERIOUS INJURY AND BURNS IF TOUCHED. IT IS THEREFORE RECOMMENDED THAT AN APPROVED FIREGUARD IS USED IN THE PRESENCE OF YOUNG CHILDREN, THE ELDERLY OR INFIRM.

CAUTION: THIS APPLIANCE SHOULD BE MAINTAINED AND OPERATED AT ALL TIMES IN ACCORDANCE WITH THESE INSTRUCTIONS.

Keep them in a safe place for future reference and when servicing the fire.
The commissioning sheet found on page 3 of these instructions should be completed by the installer.

Contents

Studio Cassette - Inset Convector

Covering the following models:

RVST-1HTAU/RVST-2HTAU/RVST-3HTAU

Appliance Commissioning Checklist	3
User Instructions	3
Installation Checklist	12
Essential Information.....	12
Installation Summary.....	13
Studio Dimensions	14
Floor Protector.....	14
Pre-Installation Instructions	15
Removal of Internal Components.....	15
Installation Instructions	18
General Points.....	18
Installation	19
Installation with a Zero Clearance Box	20
Masonry Installation.....	30
All Installations.....	33
Fitting the Flue Collar	33
Installation of the Inner Box.....	34
Fitting of Internal Components.....	34
Alarms	37
Commissioning.....	38
Maintenance & Servicing.....	39
Technical Appendix.....	43
Spare Parts List.....	50
Service Records	58



Design Protection

Warranty

The Studio design, including it's frames and accessories, are protected by European Design Registration No. 001169338 0002 0008.

See rear of instructions for servicing details and full warranty terms and conditions.

Appliance Commissioning Checklist

This checklist **MUST** be filled out completely and signed in order to qualify for the full Dealer Warranty. Failing to complete this commissioning checklist will mean the warranty will only be valid for 12 months from the date of purchase.

Dealer appliance was purchased from:

Name: _____

Address: _____

Telephone number: _____

Essential information - MUST be completed:

Date Installed: _____

Model Description: _____

Serial Number: _____

Installation Technician:

Company Name: _____ AHHA/SFAIT License No _____

Address: _____

Telephone number: _____

Commissioning Checks - to be completed and signed:

Is flue system correct for the appliance:	YES <input type="checkbox"/>	NO <input type="checkbox"/>
Flue swept and soundness test complete*:	YES <input type="checkbox"/>	NO <input type="checkbox"/>
Smoke test completed on installed appliance	YES <input type="checkbox"/>	NO <input type="checkbox"/>
Spillage test completed	YES <input type="checkbox"/>	NO <input type="checkbox"/>
Use of appliance and operation of controls explained	YES <input type="checkbox"/>	NO <input type="checkbox"/>
Clearance to combustible materials checked**	YES <input type="checkbox"/>	NO <input type="checkbox"/>
Instruction book handed to customer	YES <input type="checkbox"/>	NO <input type="checkbox"/>
Smoke Alarm Fitted (Mandatory)	YES <input type="checkbox"/>	NO <input type="checkbox"/>
CO Alarm Fitted (Recommended)	YES <input type="checkbox"/>	NO <input type="checkbox"/>

*If using an existing flue system - not applicable for a new flue assembly
** Record with photographs if possible.

Signature: Print Name:

Getting Started

1. General Points

- 1.1 Before use of this appliance please read these instructions fully and carefully to ensure that you have fully understood their requirements.
- The appliance must be fitted by a licensed installer, or approved by your local building control officer.
- 1.2 All local regulations and national standards need to be complied with when installing the appliance.
- 1.3 Only use for domestic heating in accordance with these operating instructions.
- 1.4 You must burn only approved fuels. Do not use with liquid fuels or as an incinerator.
- 1.5 **WARNING: DO NOT USE FLAMMABLE LIQUIDS OR AEROSOLS OR PLACE THESE IN THE VICINITY OF THIS APPLIANCE WHEN IT IS OPERATING.**
- 1.6 **WARNING: DO NOT STORE FUEL WITHIN THE HEATER INSTALLATION CLEARANCES.**
- 1.7 **CAUTION: THIS APPLIANCE SHOULD NOT BE OPERATED WITH CRACKED GLASS.**
- 1.8 Please note that all parts of these stoves and particularly the glass panel in the door become extremely hot during operation and can result in serious injury and burns if touched. It is therefore recommended that a approved fireguard is used in the presence of young children, the elderly or infirm.
- 1.9 Do not place photographs, TV's, paintings, porcelain or other combustible items on the wall or near the appliance. Exposure to hot temperatures will cause damage. Do not place furniture or other items such as drying clothing closer than 1m from the front of this appliance.
- WARNING:** Extra fuel should not be stored on or next to the appliance. Only keep enough fuel for immediate use nearby and never leave the appliance unattended for long periods with any combustible material in close proximity.
- 1.10 Extractor fans or cooker hoods must not be positioned in the same room as the appliance, as they evacuate room air and can cause fumes to vent back into the room.
- 1.11 Do not obstruct room air replacement ventilation required for the safe use of this appliance.
- 1.12 **WARNING: ANY MODIFICATION OF THE APPLIANCE THAT HAS NOT BEEN APPROVED IN WRITING BY THE TESTING AUTHORITY IS CONSIDERED TO BE IN BREACH OF THE APPROVAL GRANTED FOR COMPLIANCE WITH AS/NZS 4013.**
- 1.13 The chimney must be swept and the appliance inspected at least once a year (see User Instructions, Section 11).
- 1.14 Do not connect, or share, the same flue or chimney system with another appliance.

SERIAL NUMBER LOCATION

- 1.15 This number is required when ordering spare parts or making warranty claims.

It is found on the appliance data plate, see Diagram 1.

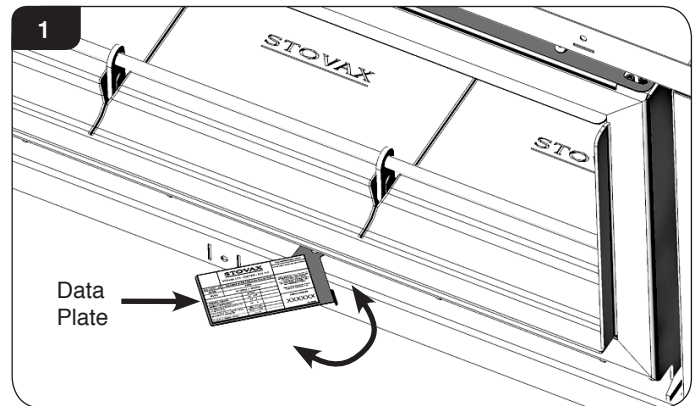

AIR CONTROLS

Stovax appliances have air systems that provide cleaner burning, and greater efficiency and control.

- 1) Primary Air - the source of Primary Combustion air when burning wood. The Primary Air Control is used to adjust the burn rate of the fire whilst air drawn over the window cleans the glass.

Open = High temperature
Closed = Low temperature

- 2) Secondary Air - Secondary air is preheated through a heat exchanger to combust unburned hydrocarbons, providing a cleaner and more efficient burn. This air supply is also factory set.

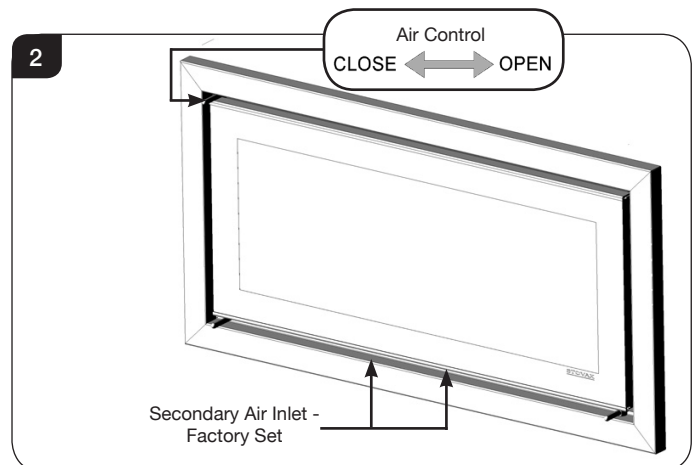

Getting Started

DOOR HANDLE

DO NOT OPEN THE DOORS WHEN THE FIREBOX IS FULL OF FLAMES - wait for them to die down

Studio 1 & 2

- 1.16 Use a protective gloved hand to operate. Slide tool over knob to fit.
- 1.17 Move to the left to open, see Diagram 3.

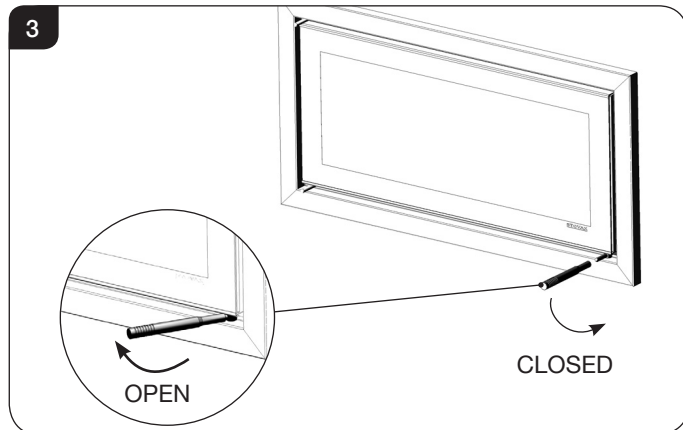

DO NOT OPEN THE DOOR WITH BARE HANDS

Studio 3

- 1.18 Engage tool in door as shown, see Diagram 4. Pull door out and down to open.

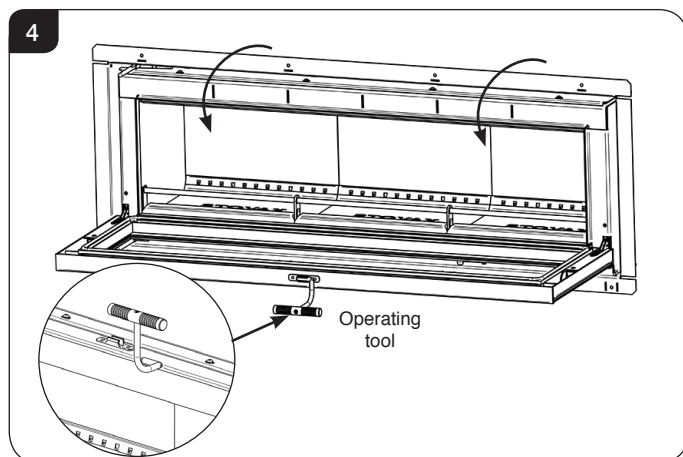

WARNING



Properly installed, operated and maintained this appliance will not emit fumes into the room but occasional fumes from de-ashing and refuelling may occur. Persistent fume emission is potentially dangerous and must not be tolerated.

If fume emission persists:

- Open doors and windows to ventilate the room.
- Leave the room.
- Allow fire to burn out or safely dispose of fuel from the appliance.
- Check for chimney blockage and clean if required.
- Do not attempt to relight until the cause of the emission has been identified and corrected.
- If necessary seek expert advice.
- All open flued appliances can be affected by temporary atmospheric conditions which may allow fumes to enter the house. Because of this it is recommended that an electronic carbon monoxide detector together with a mandatory smoke alarm be fitted and maintained.

IF THE ALARM SOUNDS FOLLOW THE INSTRUCTIONS GIVEN UNDER WARNING ABOVE.

2. Using The Appliance For The First Time

- 2.1 To allow the appliance to settle, and fixing glues and paint to fully cure, operate the appliance at a low temperature for the first few days.
- 2.2 Do not touch the paint during the first period of use.
- 2.3 During this time the appliance may give off some unpleasant odours. Keep the room well ventilated to avoid a build-up of fumes.
- 2.4 Please be aware that, during use, rope seals may discolour. This is normal.

Getting Started

3. Recommended Fuels

3.1 Wood Logs:

Burn only seasoned wood timber with a moisture content of less than 20%. To ensure this allow cut wood to dry for 12 to 18 months.

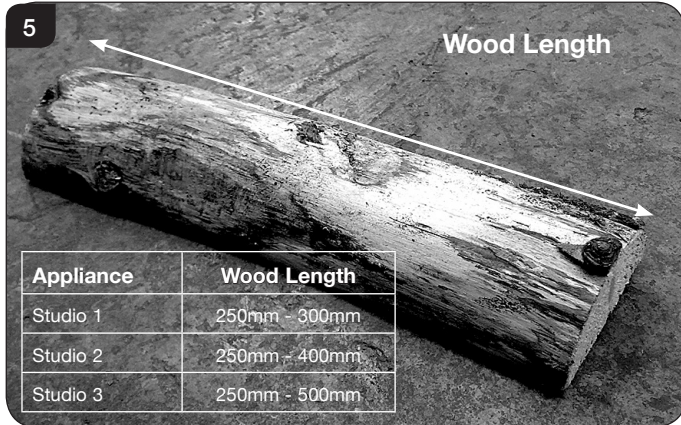

Wood logs should be stored in a well ventilated, dry, covered area.

Poor quality timber:

- Causes low combustion efficiency.
- Produces harmful condensation.
- Reduces effectiveness of the Upper Primary Control and life of the appliance.



Do not burn construction timber, painted, impregnated / treated wood, manufactured board products or pallet wood.

CAUTION: THE USE OF SOME TYPES OF PRESERVATIVE-TREATED WOOD AS A FUEL CAN BE HAZARDOUS.

4. Lighting the Appliance

4.1 For best results set air control as shown, see Diagram 6.

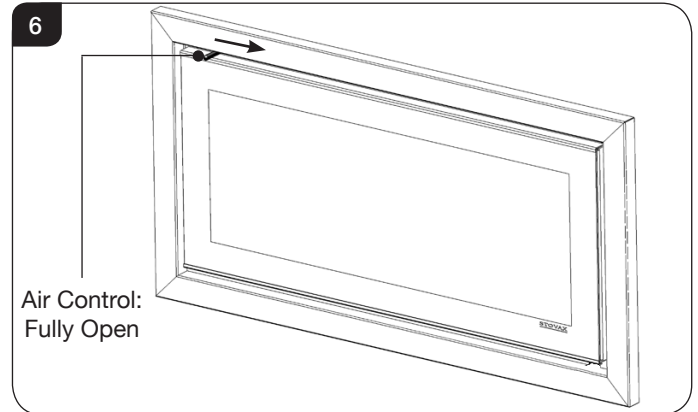

WARNING: DO NOT USE FLAMMABLE LIQUIDS OR AEROSOLS TO START OR REKINDLE THE FIRE.

4.2 Place firelighters or paper and dry kindling wood on the base.

A successful fire initially requires plenty of kindling to establish a hot firebox and warm the chimney to aid flue performance.

4.3 Light the paper or firelighters.

4.4 Leave the door slightly open for a few minutes as the fire establishes and the glass warms. This will avoid build up of condensation.

4.5 Add larger pieces of wood.
Do not use full sized logs at this stage, build up gradually in size. Too many logs may smother the fire.

Fuel Loading:

These are wide appliances and the logs should be laid out in a single layer with gaps between, see Diagram 7.

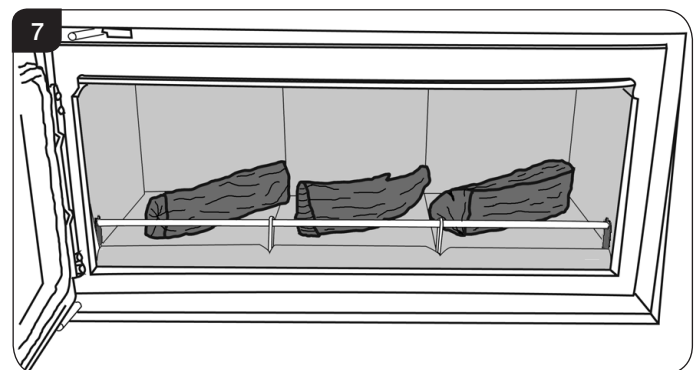

Suggested Loads:

Studio 1 & 2 - 3/4 logs no bigger than 5" (127mm) diameter
Studio 3 - 4/5 logs no bigger than 5" (127mm) diameter

User Instructions

Do not stack the logs on top of each other as this could effect the efficiency.
DO NOT OVERLOAD THE APPLIANCE AS THE HEAT OUTPUT WILL BE TOO HIGH AND CAN LEAD TO PERMANENT DAMAGE TO THE APPLIANCE.

Be sure to use split logs and not whole pieces of wood. Too much fuel in the firebox will cause the appliance to reach higher temperatures than intended. This can damage the interior components of the fire.

4.6 Close the door.



WARNING: DO NOT OPERATE THE APPLIANCE WITH THE AIR CONTROL FULLY OPEN FOR LONG PERIODS OF TIME AS THIS COULD CAUSE OVER-FIRING AND MAY CAUSE PERMANENT DAMAGE.

5. Running the Appliance

Burning Wood

5.1 Use the Air Control to control the burn rate to achieve the desired temperature, see Diagram 8.

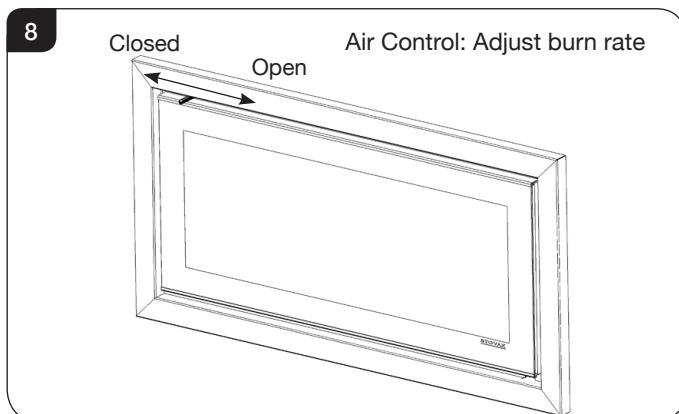

Wood burns best on a bed of ash (approx. 25mm (1") deep).

5.2 Under normal circumstances **do not** burn large amounts of fuel with the Air Control closed for long periods of time. This reduces the glass cleaning effect, causes tars and creosotes to build-up in the appliance and flue system and will produce excessive amounts of smoke.

5.3 When in use, burning the appliance at a high temperature for a short period reduces tars and creosotes.

Experience establishes settings to suit personal preference.

A bright and clean firebox indicates the appliance is burning well.

BURN BRIGHT BURN RIGHT.



WARNING: DO NOT OPERATE THE APPLIANCE WITH THE AIR CONTROL FULLY OPEN FOR LONG PERIODS OF TIME AS THIS COULD CAUSE OVER-FIRING AND MAY CAUSE PERMANENT DAMAGE.

Refuelling

5.4 Toward the end of the burn cycle open the Air Control for a few minutes. This increases the temperature of the ashbed, helping re-ignition of the new logs and keeps the ash to a minimum.

5.5 **CAUTION: OPEN AIR CONTROL BEFORE OPENING THE DOOR.**

5.6 Rake the embers evenly over the firebed and open the **Control** fully for a few minutes before re-fuelling.

5.7 Stack the logs in an open arrangement, see Section 4.5.

Open stacking allows oxygen to easily reach every part of the fire.

Compact stacking will make the wood burn slower as air can only reach the outside of the fire. This will cause the fire to smoulder and produce smoke.

5.8 **Burn the new logs at high temperature for a few minutes before closing the Air Control. Use the Air Control to adjust the burn rate to maintain combustion at the desired level.**
Open = High temperature, Closed = Low temperature.

Do not close the Air Control until the fire is burning well. If the flames die away completely open the air control until flames re-establish.

Experience over time will dictate the ideal settings.

Shut Down

5.9 If there is still burning fuel in the firebox, Stovax do not recommend shutting down the Air Control completely unless there is a chimney fire in progress (see Section 10 for advice). Closing the control during the burning process will cause poor combustion and could lead to a build up of gasses that could ignite dangerously.

5.10 Always have enough air entering the stove to maintain some flame within the firebox.

5.11 If it is necessary to shut down the appliance then run on a high setting until all of the fuel has been burnt before closing the Air Control.

User Instructions/ Care & Maintenance

6. Extended Burning

- 6.1 It is possible to get the appliance to burn for extended periods of time. In order to do this:
- De-ash prior to final refuelling.
 - Set Air Control to low combustion settings.
This will gradually blacken the glass but it will clear when operated at a high temperature for a short period.

7. Ash Removal

- 7.1 Wood burns best on a bed of ash approximately 25mm deep.
Do not allow ash to build up in the appliance as it will not burn properly and may cause damage.
- 7.2 Open door, see Diagram 3 on page 5.
- 7.3 Remove ash carefully with a small shovel (available from Stovax) - **heat can remain long after use**. Take care not to damage the ceramic lining of the appliance. Do not use sharp pointed pokers.
- 7.4 Carefully place the ash into a Stovax Ash Caddy (Stovax Part No. 4227) and take immediately outside to an area free from combustible material.
- 7.5 Only place ash in a non-combustible container with a tightly fitting lid.

8. When not in use

- 8.1 If the appliance is not used for long periods of time, during the warmer months for example, it should be cleaned and serviced as detailed in the Maintenance and Servicing section.
- 8.2 Set the Air Control to 50% to keep the appliance ventilated and stop the build-up of any moisture inside.

Before re-lighting the appliance:

- **Remove the baffles and clear any debris that may have accumulated above them.**
- **Check the flue is clear of any blockages.**

9. Over-Firing

- 9.1 Do not over-fill with fuel or run at high temperatures for long periods or over-firing can occur.
DO NOT OPERATE THE APPLIANCE WITH THE PRIMARY AIR CONTROL OPEN FOR LONG PERIODS OF TIME AS THIS COULD CAUSE OVER-FIRING AND MAY CAUSE PERMANENT DAMAGE.
- 9.2 **Over-firing can cause permanent damage to the appliance and invalidate the product warranty.**

10. Chimney Fire

- 10.1 **If a chimney fire occurs:**
- **Shut all air controls immediately.**
 - **Evacuate the building.**
 - **Call the fire brigade.**
 - **Do not re-enter the building until it is confirmed safe.**
- 10.2 **Do not use the appliance after a chimney fire until:**
- a) **It has been inspected by a registered installer, confirming the appliance is safe to use.**
 - b) The chimney system has been inspected and swept by a chimney sweep, confirming the system is structurally sound and free from obstruction.
 - c) **It is repaired as required before re-use.** Use only genuine Stovax replacement parts to keep your appliance in safe, efficient working order.

11. Chimney Sweeping & Appliance Inspection

- 11.1 To maintain safe and efficient use of the appliance, the chimney/flue must be inspected and swept at least once a year and the appliance inspected by an appropriately qualified chimney sweep.
- If the appliance is used continuously throughout the year more frequent sweeping and inspection is recommended.
- The best time to have the chimney swept is at the start of the heating season.
- 11.2 The chimney, any connecting flue pipe and the appliance flue ways, if incorporated, must be regularly cleaned.
- 11.3 It is possible to sweep the chimney through the appliance once the baffles have been removed.
- 11.4 See Maintenance & Servicing section at the rear of this manual for further information.

Care & Maintenance

12. Care Of Stove



Stovax has a range of cleaning and maintenance products and accessories to keep your appliance in good working order. Your Stovax retailer can advise you on suitable items for your stove and provide genuine spare parts such as replacement glass, door sealing rope and firebricks. View the extensive range at www.stovax.com by clicking on Accessories. In addition, an annual service by a competent technician is recommended to keep your stove in the best possible condition.

- 12.1 Clean and inspect the appliance regularly, especially in periods of heavy use. Regular cleaning and maintenance will help give many years of safe use.
- 12.2 **Allow the appliance to cool thoroughly before cleaning to avoid risk of burns.**
- 12.3 Keep the glass clean with the correct use of the Air Control system and good quality fuel.
- 12.3 Check the condition of the glass and clean if necessary.

Note: Do not use the appliance if the glass is damaged in any way.
- 12.4 Sometimes additional glass cleaning may be required.
 - Allow appliance to cool fully. Do not clean hot glass.
 - Use a soft cloth and Stovax Glass Cleaner.
- 12.5 **Do not use cleaning agents that have a high alkaline content, for example Stovax Gel Cleaner, on appliances with painted glass. These are abrasive cleaning agents that are designed to be used with heavily stained clear glass. Use Stovax Glass Cleaner (Stovax No.4103) on more delicate surfaces.**
- 12.6 Before re-lighting the appliance dry the glass fully.
- 12.7 Check the condition and security of the door rope seals and replace if seals are no longer intact.
- 12.8 Remove the ash completely, see Section 7.
- 12.9 Check the internal components for damage (bricks and baffles) and for obvious build up of soot, ash or debris above the flue baffle(s) (these can be found in the upper part of the firebox). Use a torch if necessary.

If there are any signs of a build up of debris above the flue baffle(s) either:

- Arrange for the chimney to be swept, see Section 11.
- Remove the baffle(s) (see Installation Instructions) and clear the debris.

12.10 To refresh painted finishes a touch up spray is available from your Stovax dealer (Stovax No.2053).

Do not use aerosol sprays near an operating appliance.

Troubleshooting

Troubleshooting

	Symptom	Cause	Solution
OPERATION	Difficulty starting the fire and keeping it burning well	Low flue draught	Consult your installer
		Wet wood (over 20% moisture)	Use dry seasoned wood (less than 20% moisture content)
	Poor burning control	High flue draught	Consult your installer
	Short burn times	Wet wood (over 20% moisture) Insufficient fuel - consult table in Section 3	Use dry seasoned wood (less than 20% moisture content)
	Excessive heat output (Over firing)	High flue draught	Consult your installer
		Air control left fully open	Close air control to reduce output
	Low heat output	Low flue draught	Consult your installer for advice on suitable flue system
		Wet wood (over 20% moisture)	Use dry seasoned wood (less than 20% moisture content)
Excessive fuel consumption	High flue draught	Consult your installer for advice on suitable flue system	
	Over dry wood	Do not use constructional timber or pallet wood	
SMOKE EMISSIONS	Smoke and small flames	Wet wood (over 20% moisture)	Use dry seasoned wood (less than 20% moisture content)
	Intermittent smoke spillage into room when appliance door is opened	Low flue draught	Consult your installer for advice on suitable flue system
		Air replacement inadequate	Consult your installer
	Continuous smoke spillage into room when appliance in use	Blocked flue	Open all doors and windows to ventilate the room. Allow the fire to burn out. Check flue for blockage. Do not re-use until cause of spillage is identified. Consult your installer for advice
Blue/grey smoke from chimney	Wet wood (over 20% moisture)	Use dry seasoned wood (less than 20% moisture content)	
ADVERSE WEATHER	Windy days, intermittent smoke spillage into room when appliance door is opened	Down draught in flue caused by air turbulence caused by nearby buildings or trees	Weather conditions combined with the flue terminal position can have an effect on the appliance performance. Consult your installer
	Calm days, intermittent smoke spillage into room when appliance door is opened	Damp heavy air and poor flue draft	Weather conditions combined with the flue terminal position can have an effect on the appliance performance. Consult your installer
	Damp/Rainy days lighting and burning problems	Low flue temperature/damp heavy air outside	Pre-heat flue with burning paper. Use good quality wood to start and maintain the fire.
	Wind noise from the air control	High flue draught	Consult your installer for advice on suitable flue system

Troubleshooting

	Symptom	Cause	Solution
THE APPLIANCE	Rapid creosote build-up in the chimney	Wet wood (over 20% moisture)	Use dry seasoned wood (less than 20% moisture content). Operate at a high temperature for short periods each time the appliance is used to avoid large build-ups of tars and creosotes
	Tar coming from exposed flue joints	Appliance operated at continuous low temperatures	Operate at a high temperature for short periods each time the appliance is used to avoid large build-ups of tars and creosotes. See user instructions for correct use of air control
		Using poor quality wood	Use dry seasoned wood (less than 20% moisture content)
	Strong pungent smell after the appliance is lit	Appliance operated at continuous low output	Operate at high output for short periods. See user instructions for correct use of air control
		Using poor quality wood	Use dry seasoned wood (less than 20% moisture content)
	Wind noise from the air control	High flue draught	Consult your installer for advice on suitable flue system
	Dirty firebricks	Wet wood (over 20% moisture)	Use dry seasoned wood (less than 20% moisture content)
	Dirty glass	Wet wood (over 20% moisture)	Use dry seasoned wood (less than 20% moisture content)
	Glass blackening	Using poor quality wood	Use dry seasoned wood (less than 20% moisture content)
		Low flue draught	Consult your installer for advice on suitable flue system
Incorrect use of air control		See user instructions for correct use of air control	
Appliance operated at continuous low temperatures		Operate at high output for short periods. See user instructions for correct use of air control	

FLUES	Smoke Spillage into room	Flue offset below 1.0m height above the appliance restricting draw	Ensure any flue offsets are at least 1m above the appliance spigot and no more than 45° off the vertical and offset is no more than 1.0m centre to centre
	The flue system has two main functions:		
	<ul style="list-style-type: none"> - To safely remove the smoke, fumes and combustion gases from the building. - To provide a sufficient amount of flue draught (suction) in the appliance to ensure the fire keeps burning. 		
	The flue draught is caused by rising hot gases when the appliance is lit.		
	Tar and creosote are a major cause of chimney fires. If the appliance experiences problems with tar build up consult a chimney sweep before continued use of the appliance.		

For advise on the correction of persistent flue problems consult a qualified heating technician before continuing to use the appliance.

Installation Checklist

Please Note

This section is intended to give an overview of the product performance and essential information required for installing the appliance. It is intended for qualified engineers who are already familiar with Stovax products.

For full details and expanded information please see the Technical Appendix at the back of this manual.

1. Essential Information

GENERAL	Model:			Studio 1	Studio 2	Studio 3
	Studio 1					
	Studio 2					
	Studio 3					
	Nominal Heat Output	Wood	kW	12	15	18
	Room Heating Capacity	Wood	m ²	150	200	250
	Particulate Emissions	Wood	g/kg	2.39	2.28	2.0
Efficiency	Wood	%	56%	60%	58%	
Weight		Kg	88	135	206	
Recommended Fuels	Wood	Seasoned Wood (less than 20% moisture content) Hardwood				

As tested to the requirements of AS/NZS 4012:2014 & AS/NZS 4013:2014.

FLUES	Flue/Chimney Size	Zero Clearance Box Factory made system (diameter) installed in accordance with manufacturers instructions	mm	150/200/250	150/200/250	150/200/250
	Flue/Chimney minimum height**	All products	m	4.6	4.6	4.6
	Flue Draught	Min	mm Wg	1.0	1.0	1.0
		Nominal		1.5	1.5	1.5
		Max		2.0	2.0	2.0
Flue Outlet Size (Top Option)		mm	153	153	153	

Flue Specification approved to AS/NZS 2918:2001

VENTILATION	Cavity Ventilation (Timber Construction)	ø	100mm x 2	100mm x 2	100mm x 2
	Room Air Replacement (vents x 2)	mm	125 x 125	175 x 175	200 x 200

For full technical details on ventilation see Technical Appendix on Page 47 m



**When measured from the top of the hearth to the top of the flue, with no horizontal sections and a maximum of 4 bends with angles of less than 45°

Installation Checklist

2. Installation Summary

This checklist is designed to help guide the installer through the process of installing the Studio and provide a quick reference guide to the sections of the Installation Instructions that will be required for this project.

It is important to fully read and understand all the sections of these installation instructions before attempting to install this appliance.

1. Check and confirm the appliance, accessories and materials selected for installation.

- a) What model of appliance - Studio 1, 2 or 3.
- b) Is the appliance to be finished with a Decorative Frame or an Edge kit? (A frame or kit must be used) See Studio Frame Instruction Manual (**PM378**).
- c) Zero Clearance Box (Timber Frame Out Installation) See Zero Clearance Box Installation Instructions (**PM667**).
- d) Fan kit (optional). See Fan Kit Installation Instructions (**PM379**).
- e) Flue Components - Triple Flue System.
- f) Heat Resistant 12mm Board **must** be used.
- g) Floor Protector (Page 14).

2. Check studwork/opening minimum dimensions for chosen Studio model (Page 21 or 30).

- a) If a fan is to be used ensure the housing is built correctly.

3. Check Ventilation Requirements and ensure the owner/builder has been made aware of the following requirements:

- a) Cavity Ventilation 2 x 100mm (Page 12).
- b) Room Air Replacement (Page 47).

4. Pre-Installation - before fitting into Studwork/Opening:

- a) Remove Door, inner components, baffle (Page 15).
- b) Separate Inner and Outer box (Page 17).

5. Construct Zero Clearance Box (Frame Out installations only) - Refer to Installation Instructions PM667.

6. Install Zero Clearance Box into Timber Studwork - Frame Out installations only.

7. Fit the Frame Brackets or Edge kit to the appliance (Page 19/PM378).

- a) Brackets and Edge kit frame must be fitted to the appliance before installation (**Page 19/PM378**).

8. If a fan is to be installed, remove fan cover on base of Studio Outer box - Refer to Fan kit Installation Instructions PM379.

9. Fit and position the Outer Box (Frame Out Page 25, Masonry Installation Page 32).

10. Fit Triple Skin Flue System through Outer Box and connect to the Flue Collar (Page 33).

- a) Seal with Fire Cement.

11. Fit Heat Resistant board panels behind the flange of the Outer Box (Frame Out installations) - Page 27.

12. Fit remaining wall panels (Frame Out installations) - Page 31.

13. Install Studio Inner Box - Page 34.

14. Fit Inner Flue Collar - Page 34.

15. Fit Internal Components:

- a) Install Firebricks in the correct position (Page 35).
- b) Fit Upper Metal Baffles.
- c) Fit Lower Baffle Bricks.
- d) Fit Log Guard

16. Commission Studio Appliance.

Installation Checklist

3. Studio Dimensions

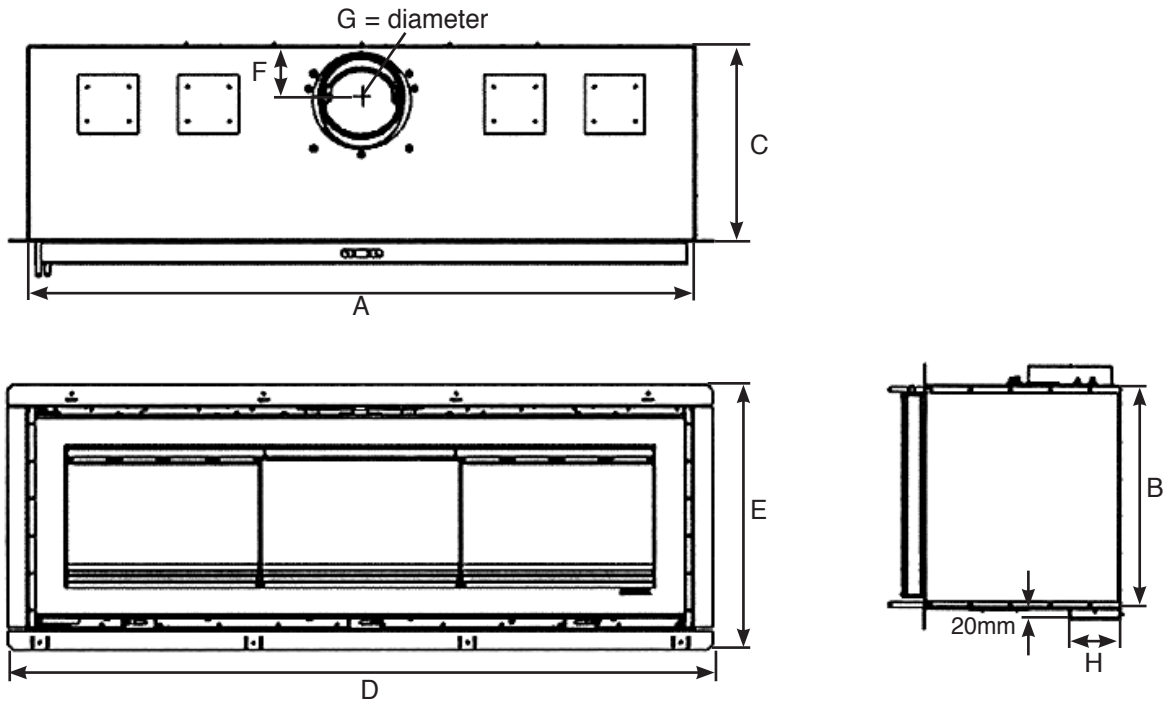

Description	Model	A	B	C	D	E	F	G	H
Studio 1	RVS1AU	745	415	350	821	497	102	153 (6")	96
Studio 2	RVS2AU	950	440	350	1019	522	102	153 (6")	105
Studio 3	RVS3AU	1332	450	393	1406	532	102	153 (6")	105

All dimensions in mm. (25.4 mm = 1")

4. Minimum Dimensions - Floor Protector

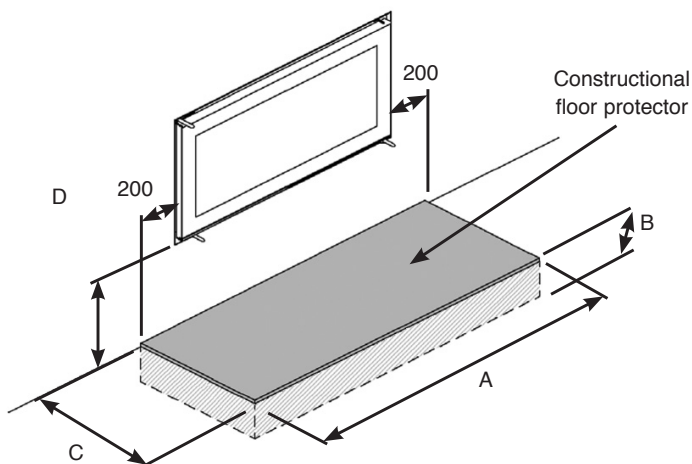

Dimension	A	B	C
Studio 1	1145	12	300
Studio 2	1350	12	300
Studio 3	1732	12	715

Dimension D:
Masonry: 250 minimum Timber: 380mm minimum

i NOTE: A hearth depth of 470mm is required for a Studio 2 fitted with a Verve frame

Pre-Installation Instructions

5. Removal of Internal Components

- 5.1 To make the installation of the appliance easier it is easier to remove the internal components before fitting into the builders opening/studwork.
- 5.2 For the best results remove the following components as set out in the sections below.

5a. Removal of the Door

Studio 1 & 2

Before removing the door it is recommended to protect the left edge from damage using masking tape.

- 5a.1 Open the door approximately 90°, see Diagram 1.

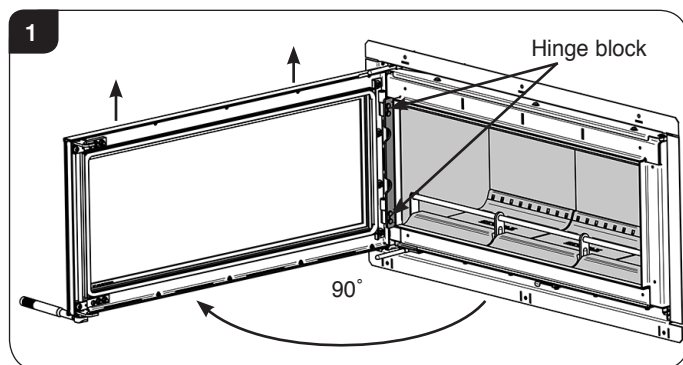

- 5a.2 Move the Air Control to the far right, see Diagram 2.

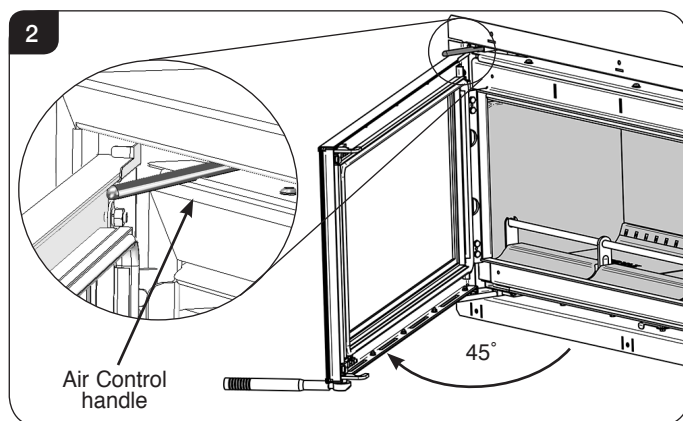

- 5a.3 Lift the door vertically to remove from the hinge block, see Diagram 1.
- 5a.4 Close the door 45°, ensuring the Air Control handle sits inside the channel in the top of the door, see Diagram 2 and carefully manoeuvre the door clear of the hinge mechanism.
- 5a.5 Lie the door face down on a soft flat surface to protect the paint work and glass.
- 5a.6 Reverse the procedure to re-fit the door.

Studio 3

This will require 2 people.

- 5a.7 Open the door fully (see User Instructions, page 6).
- 5a.8 Lock the hinges in position using a $\varnothing 3\text{mm}$ pin as shown in Diagram 3.

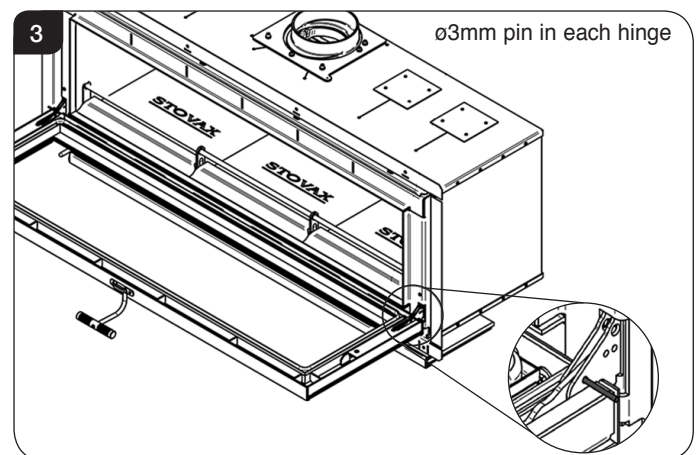

- 5a.9 Raise the door vertically at the front.
- 5a.10 Lower the door approximately 5mm and pull away from the appliance.
- 5a.11 Lie the door face down on a soft flat surface to protect the paint work and glass.
- 5a.12 Reverse the procedure to refit the door.

5b. Removal of Internal Components

In the firebox of the Studio are several loose items including:

- A box containing the Baffle Bricks and Firebricks
- A bag containing Instruction Manual, Warranty & Door Tool
- Log Guard
- Front Baffle Support

- 5b.1 Remove these carefully and put them safely to one side. They can be fitted after the appliance has been installed, see Installation Section.

Pre-Installation Instructions

5c. Removal of the Top Baffles

The appliance is fitted with baffles in the top of the firebox to maintain efficient combustion.

- Studio 1 has 1 baffle.**
- Studio 2 has 2 baffles.**
- Studio 3 has 3 baffles.**

5c.1 Once the loose internal components have been removed it is possible to remove the metal Top Baffles.

Ensure the appliance is cold before removing the baffle system.

DO NOT MODIFY THE BAFFLE SYSTEM.

DO NOT OPERATE WITH THE BAFFLE SYSTEM REMOVED.

Studio 1

This model has a single section baffle.

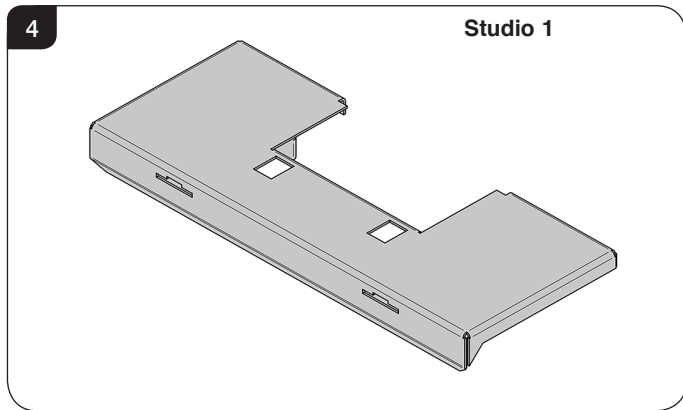

Studio 2

The Studio 2 baffle comes in two sections. To remove the baffle system first disengage the left hand side. The method of removal is the same for both sections.

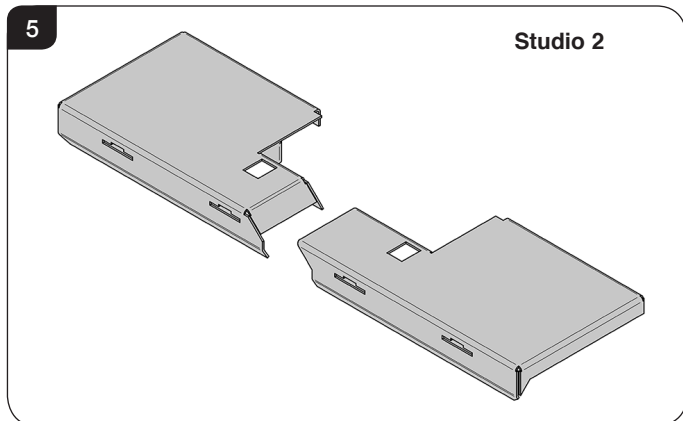

Studio 3

The Studio 3 baffle comes in three sections. To remove the baffle system the baffles must be taken out in the following order:

- Left hand side (1)
- Middle (2)
- Right Hand side (3)

The method of removal is the same for all sections.

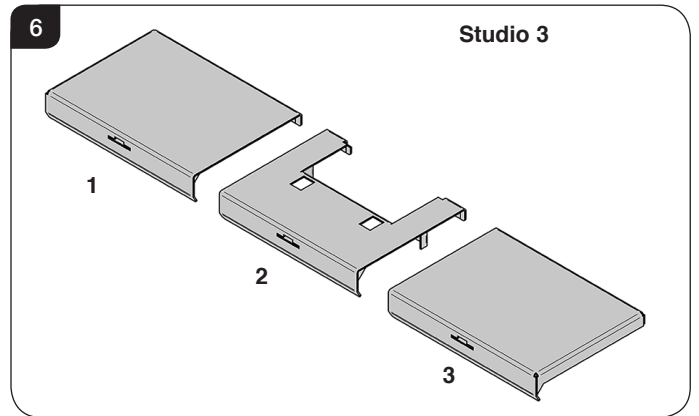

All Models

5c.2 Use two hands and lift the front edge of the baffle to clear the support tabs at the front of the firebox. Push the baffle towards the back of the appliance to free it from the tabs at the front, see Diagram 7.

5c.3 Lower the baffle into the firebox to disengage from the support pins and carefully withdraw through the front of the appliance, see Diagram 7.
Take care not to damage the firebricks.

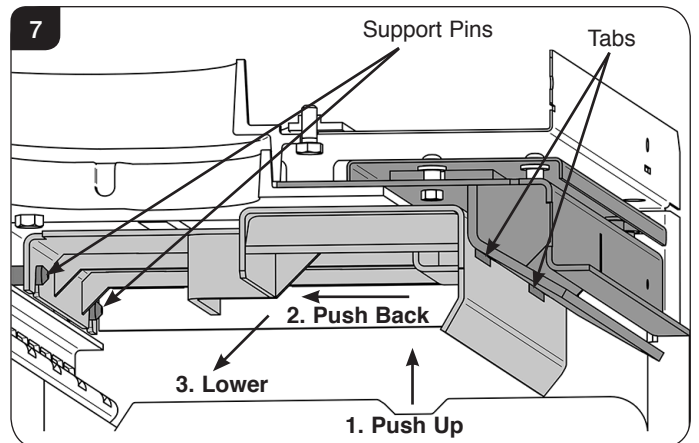

5c.4 If the appliance has more than one baffle remove in the correct order.

5c.5 Replace in reverse order.

5c.6 The baffle system is designed to give safe and efficient operation of the stove. Replace damaged baffles immediately.

Pre-Installation Instructions

5d. Separate the Inner & Outer Box

This will require two people.

To protect the delicate parts of the appliance the product has been designed so that the inner box can be removed from the outer box.

Keep the inner box in a safe place whilst the outer box is installed into the fabric of the house, the main flue connections made and the walls finished.

When all the heavy work is complete the inner box can be re-installed into the outer box and the final connection made.

Take care when installing the appliance. Careless handling and use of tools can damage the finish and/or area.

5d.1 First remove the inner collar, see Diagram 8.

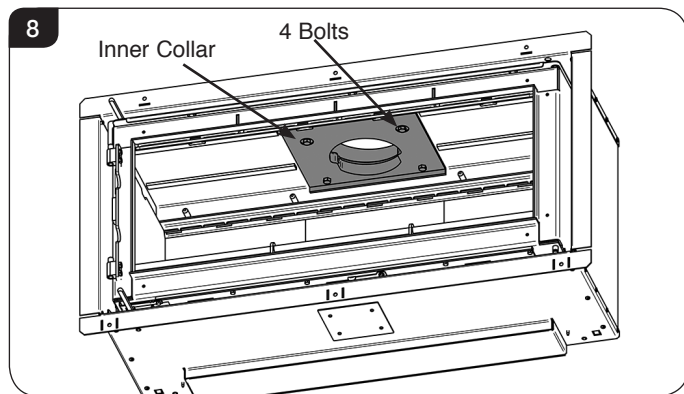

5d.2 The 2 x longer front bolts are recessed into the collar, see Diagram 9.

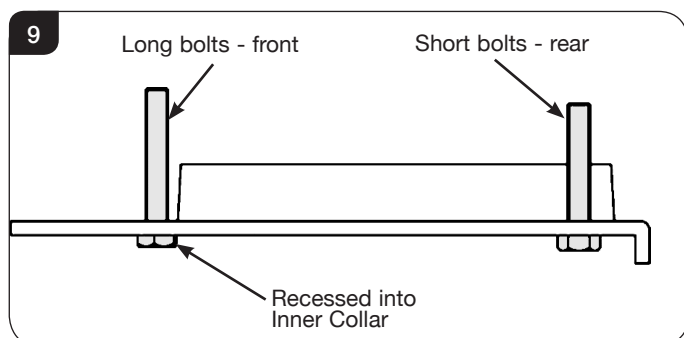

5d.3 The inner box can now be slid out of the outer box. **There is a roller assembly at the rear which locates in cutouts on the outer box, see Diagram 10.**

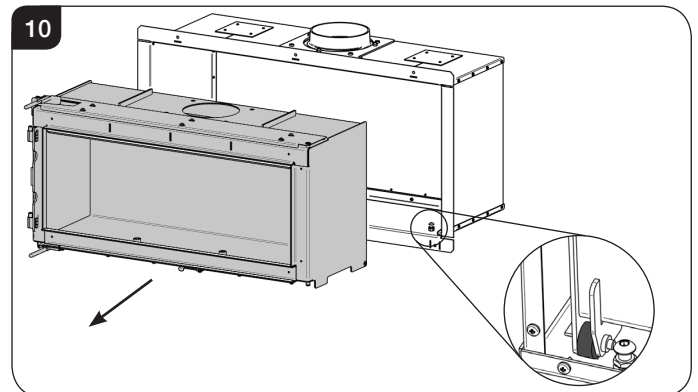

Pull the inner box carefully forward to release from the cutouts. It should now slide smoothly out of the outer box.

This will require at least two people.

Installation Instructions

Installing the Appliance

There are two methods of installing the appliance:

- Installation with Zero Clearance Box - Page 20

Installation instructions for New Build timber construction using a Zero Clearance Box.

- Masonry Installation - Page 30

For Retro Fit or New Build Masonry construction.

1. General Points

Each installation is unique to the property so it is not possible to give details to suit every setting. The installation must comply with Building Regulations and be made using "best practice" construction methods.

Stovax Studio appliances can reach high temperatures so it is important to maintain the clearance to heat sensitive materials and ensure the housing for the appliance is built from heat resistant material.

- 1.1 Take care when installing the appliance. Careless handling and use of tools can damage the finish and/or area.
- 1.2 **Use of a Zero Clearance Box allows the Studio to be installed into a timber frame out. This requires assembly prior to installation - please see separate instructions provided with the Zero Clearance Box PM667.**
- 1.3 Other heat resistant materials may also be used to create a housing for the appliance but it is essential to maintain the clearances to heat sensitive material.
- 1.4 All methods of installation will require the attachment of frame fixing brackets prior to the installation of the outer box see Frame Section, Page 19.

2. Installation

- 2.1 Refer to the diagrams and dimensions on the following pages when building a frame out to house the appliance.

If installing the Studio with an 'Edge' frame carefully read the section on Edge Installation when constructing the frame out to house the appliance.

Installation Instructions

3. Frames

3.1 There are two options that can be used to finish the look of the Studio range:

1. Decorative Frame Range.
2. A stylish 'Edge' finish.

ALL FIXING BRACKETS MUST BE FITTED PRIOR TO INSTALLING THE OUTER BOX.

Decorative Frame Range

3.2 Attach the Studio frame fixing brackets to the fire, see Diagrams 1 & 2.

See the frame fitting instruction for the individual fixing methods.
(Not required if Edge frame is fitted)

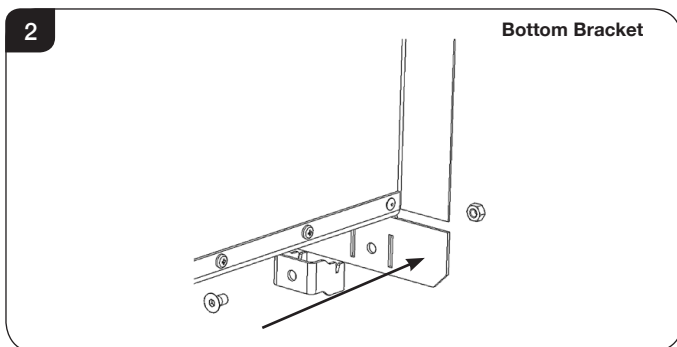
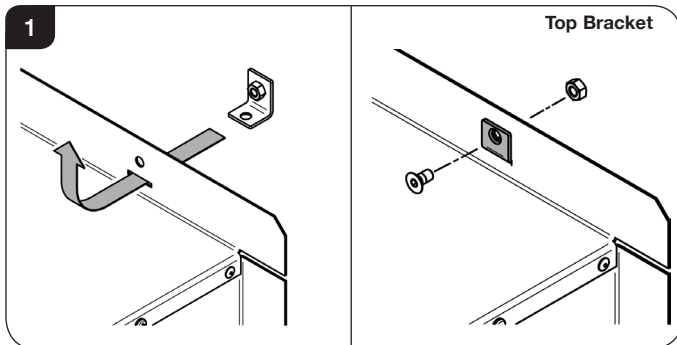

DO NOT ATTACH THE FRAME AT THIS STAGE.

3.3 The decorative frames should only be fitted after the appliance has been fully installed and all commissioning tests have been completed. Refer to the instructions supplied with the frame (PM378) for full details.

Frameless Edge

The fitting of the frame requires 2 people

3.4 Line up the frame with the holes on the appliance body, see Diagram 3.

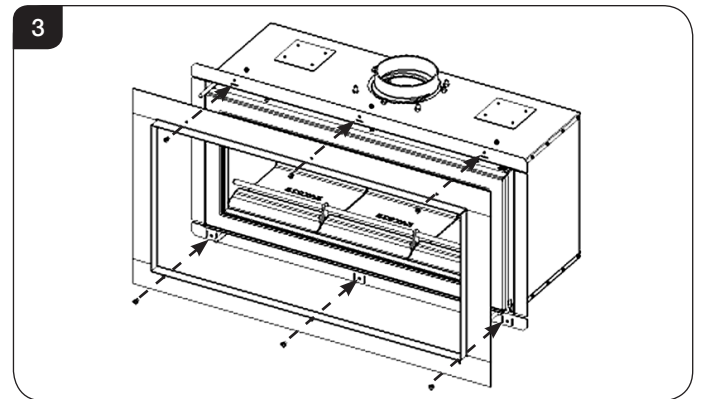

3.5 Secure the frame to the appliance body using the screws and nuts provided, see Diagram 4.
Studio 1 - 5x Screws and nuts.
Studio 2 - 6x Screws and nuts.
Studio 3 - 8x Screws and nuts.

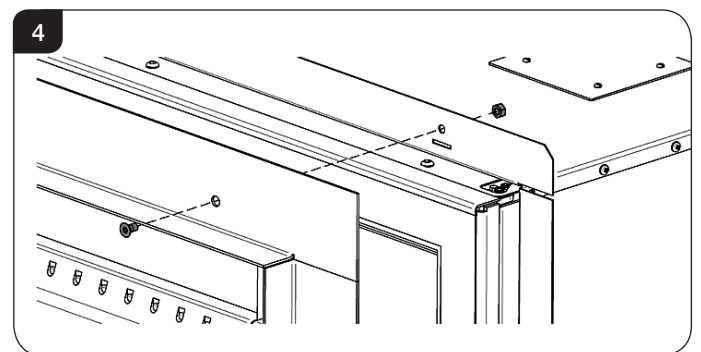

3.6 The decorative finish is part of the installation of the appliance. Carefully read the section on Edge Installation, see Section 9, when constructing the frame out to house the appliance.

Installation Instructions - Zero Clearance Box

Installation with Zero Clearance Box

4. Dimensions

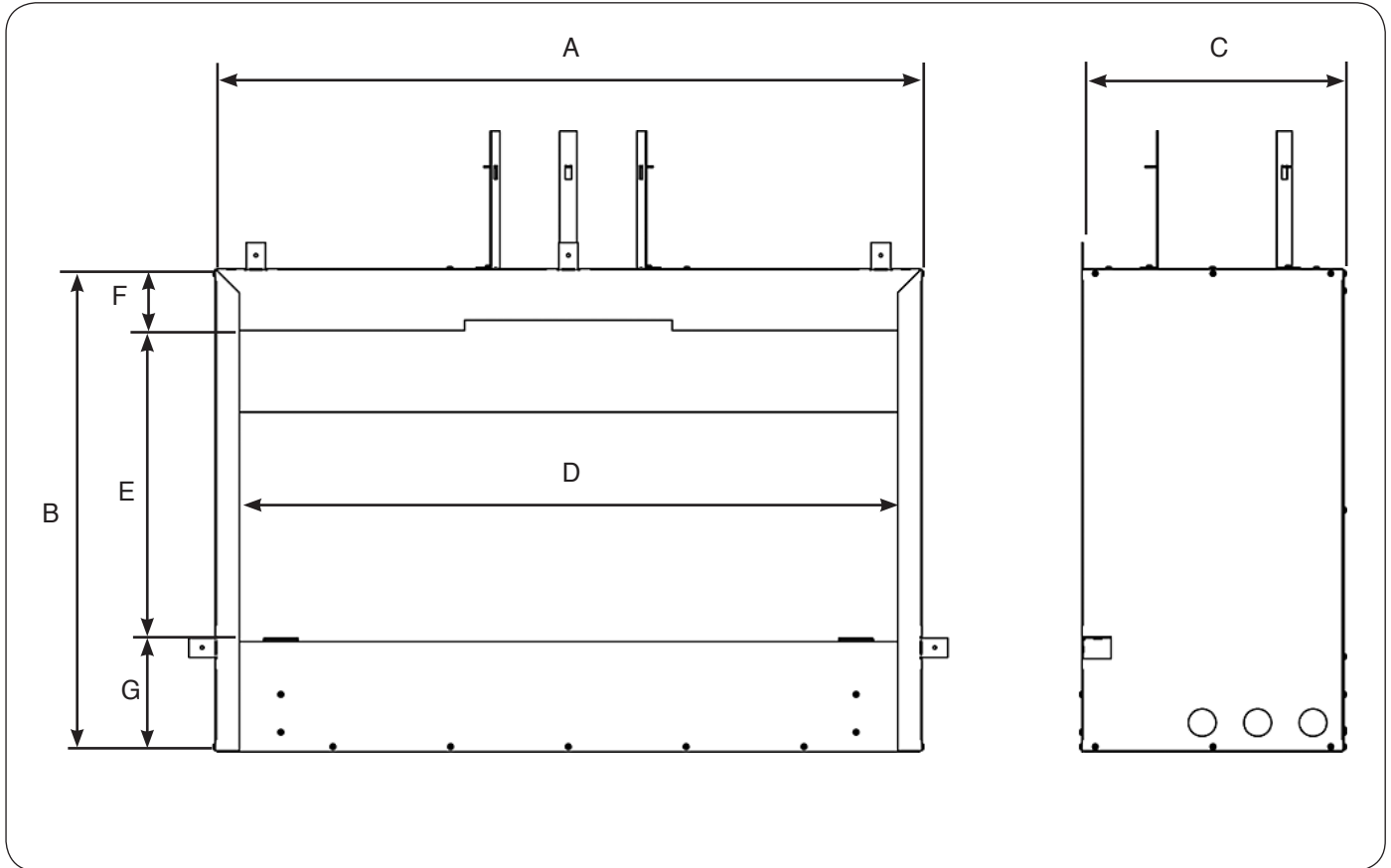

Model	A	B	C	D	E	F	G
Studio 1	820	679	378	750	429	90	160
Studio 2	1020	702	378	950	452	90	160
Studio 3	1407	713	423	1337	463	90	160

Please refer to installation instructions supplied with the Zero Clearance Box PM667

Installation Instructions - Zero Clearance Box

5a. Dimensions - Typical Frame Out



NOTE: See Section 9 for installation as an Edge finish. A different method of construction is required for the Frame Out.

Typical construction

90 x 45mm timber

90 x 12mm heat resistant board

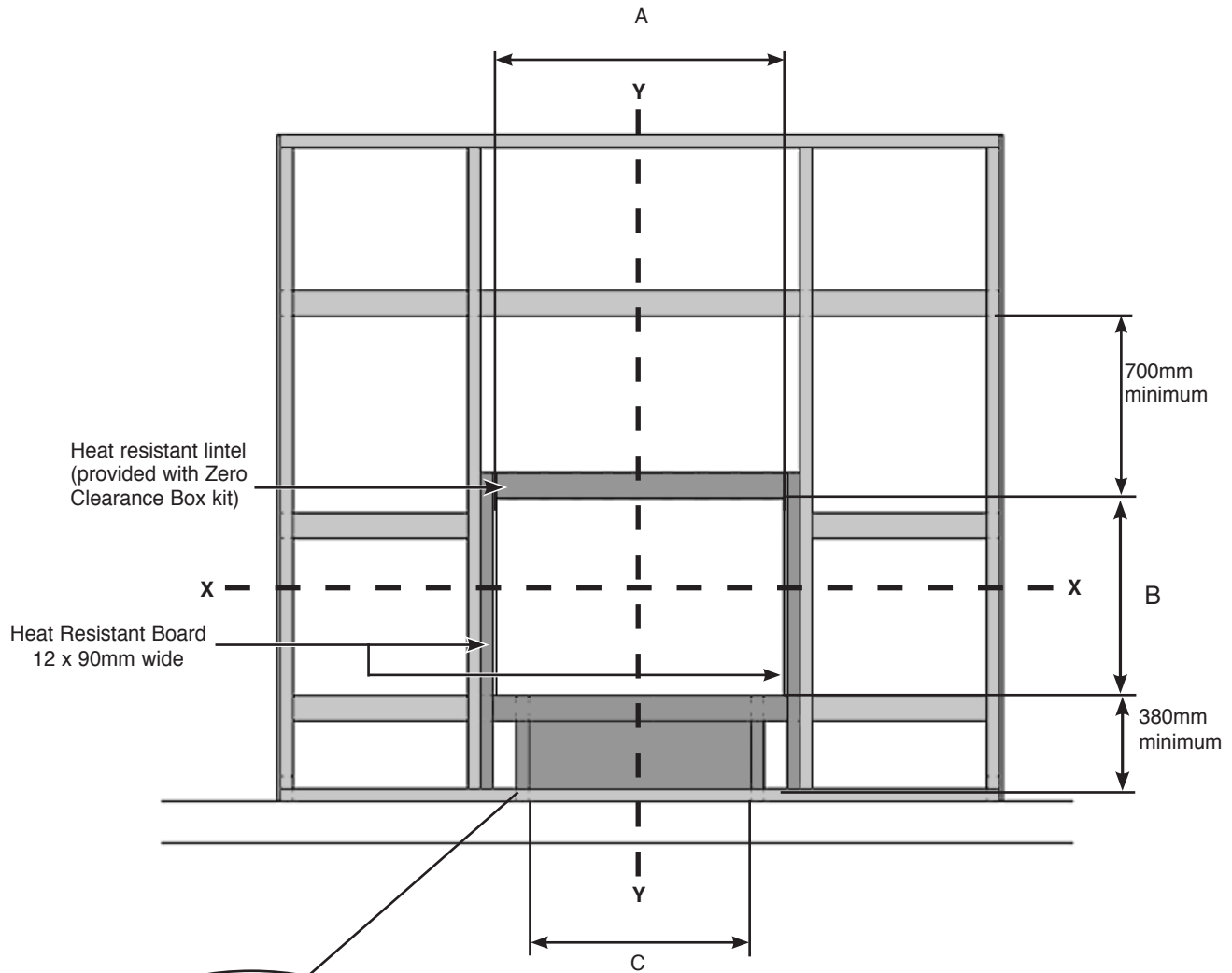

(frame out for optional fan - not required if fan not being installed)

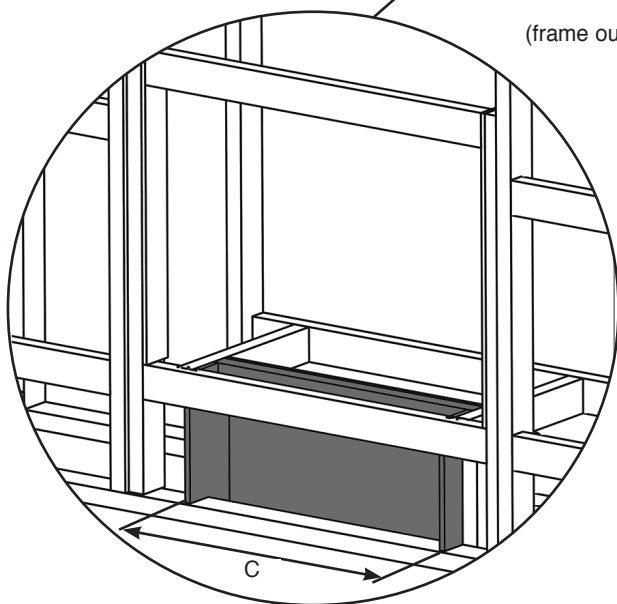

Model	A	B	C
Studio 1	830	689	605
Studio 2	1030	712	750
Studio 3	1417	723	1300

Installation Instructions - Zero Clearance Box

5b. Dimensions - Typical Frame Out continued

Section Y - Y

 No heat sensitive material in this area

Model	A	B	C
Studio 1	830	689	605
Studio 2	1030	712	750
Studio 3	1417	723	1300

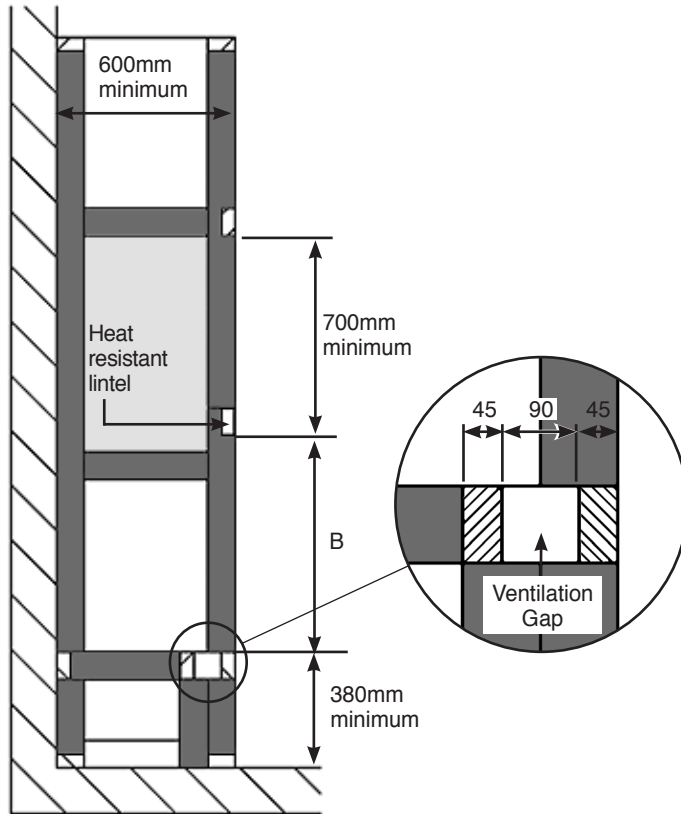

Section X - X

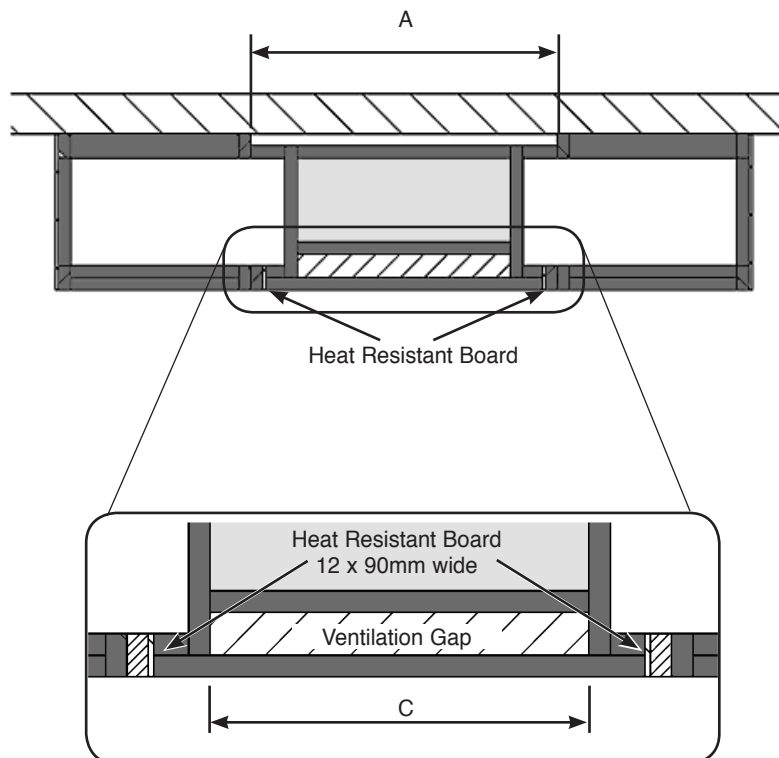

Installation Instructions - Zero Clearance Box

5c. Dimensions - Heat Resistant Board Area

IT IS ESSENTIAL THAT NO HEAT RESISTANT MATERIALS ARE USED IN THE AREAS INDICATED WHEN CONSTRUCTING THE FRAME OUT.

Model	A	B
Studio 1	750	420
Studio 2	955	445
Studio 3	1337	463

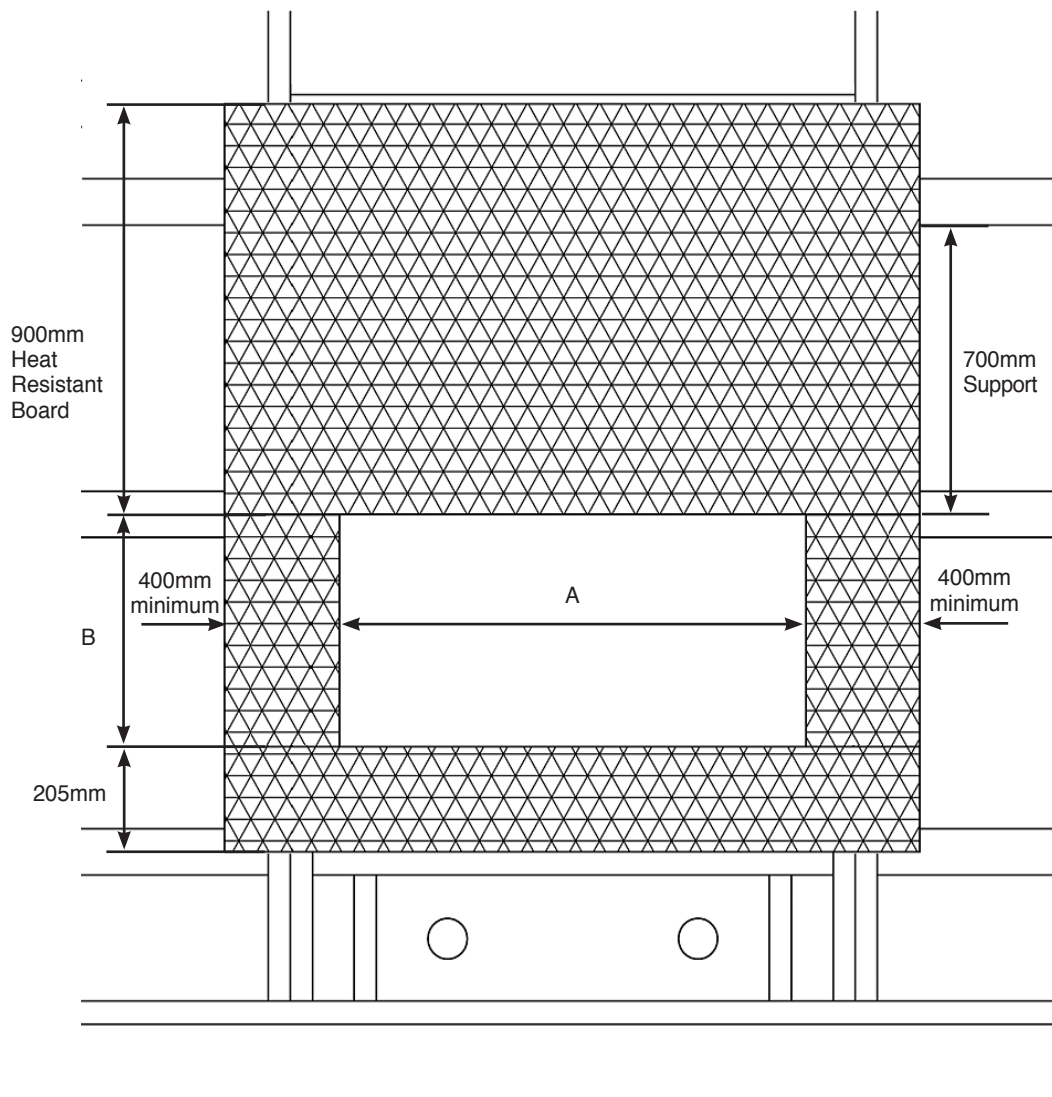

Installation Instructions - Zero Clearance Box

6. Frame Out - Typical Installation Example

IMPORTANT: NEVER POSITION A TELEVISION OR SCREEN ABOVE THIS APPLIANCE.

An access hatch must be left in the side of the chimney breast for future servicing and inspection of the flue and appliance.

- 6.1 For dimensions of the timber frame out opening, refer to the table on Page 21.
- 6.2 Cut 2 x 100mm diameter cavity air ventilation holes in the external wall behind the timber frame out. These holes must be 200mm above floor level and either side of the centre line, see Diagram 1.

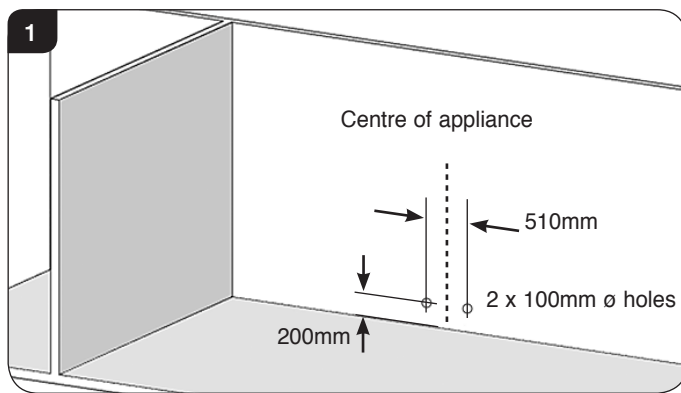

- 6.3 Build up the framework as required using 90mm x 45mm timber, see Diagram 2. Ensure the structure is secured to the wall and floor of the building.

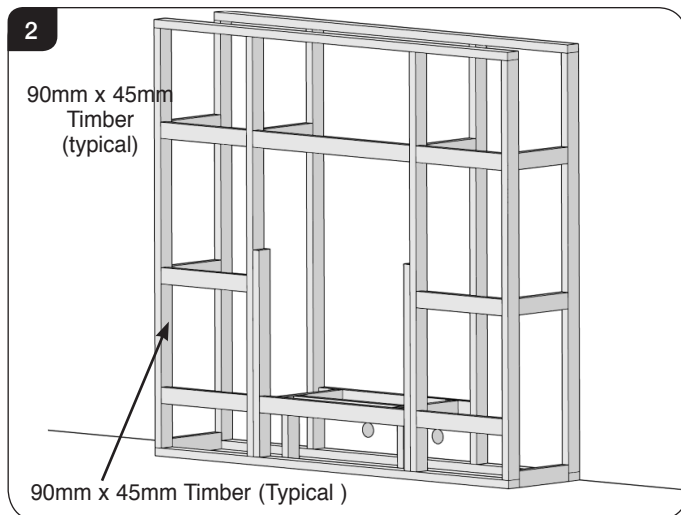

- 6.4 Fit strips of heat resistant board 90mm wide x 12mm thick to the inside of the frame opening as shown in Diagram 3.

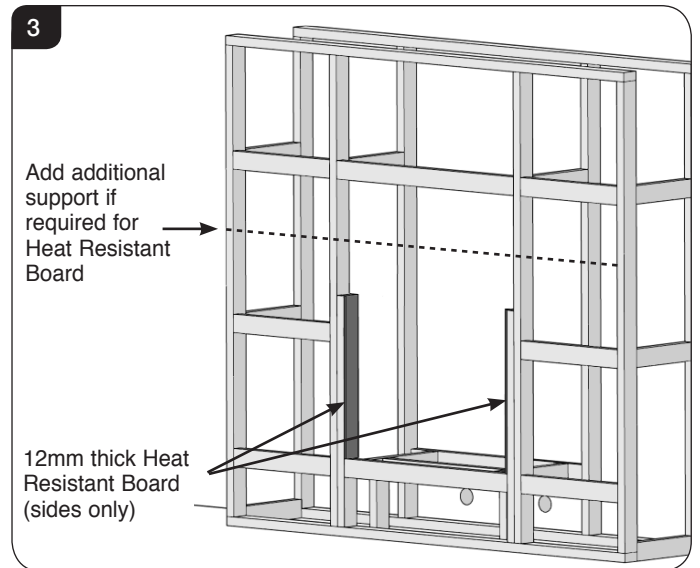

i **ADDITIONAL SUPPORT MAY BE REQUIRED BEHIND MATERIAL JOINTS DEPENDING ON BOARD LAYOUT.**

- 6.5 Fix the steel lintel into position at the top of the opening. There must be 12mm of heat resistant board between the end of the lintel and the timber frame, see detail in Diagram 4.

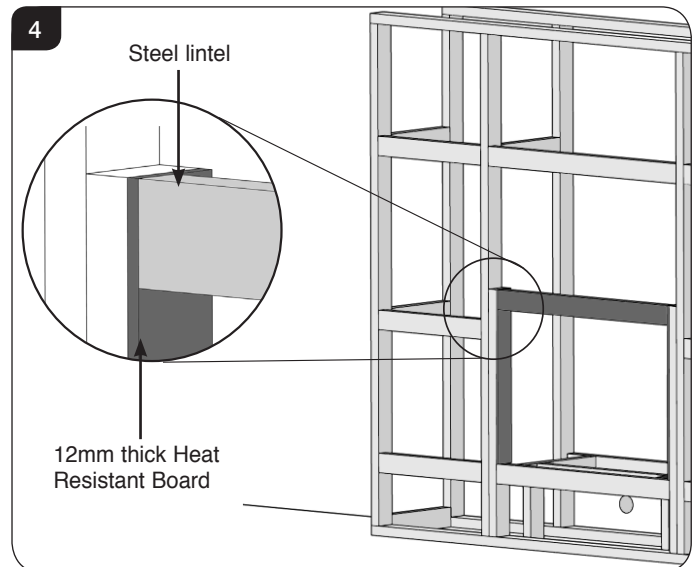

Installation Instructions - Zero Clearance Box

- 6.6 If fitting a fan kit, create a housing in the shaded area. Leave the top open to provide an air inlet for the fan. This is to ensure that room air is sufficient to the fan in preference to cavity air.

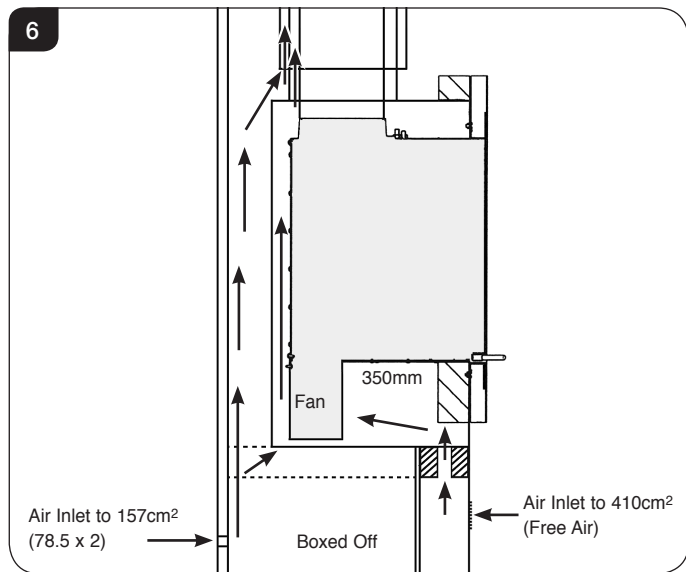
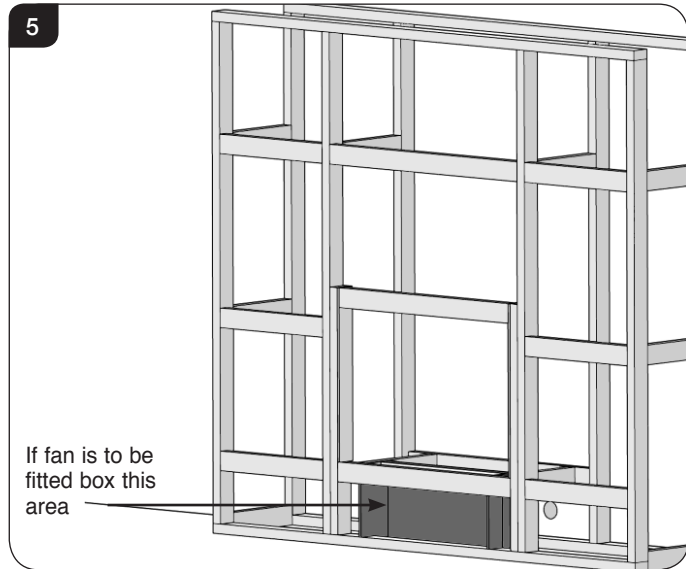

- 6.7 Remove the tall flue supports from the top of the Zero Clearance Box (if installing with a rigid flue system).

Bend the 5 fixing tabs (3 x top, 2 x sides) out at 90°.

Position the Zero Clearance Box and secure to the frame out using self tapping screws through the tabs. The side tabs should be flush with the face of the frame out.

Drill and screw through the base of the box to fit to the support runner underneath.

Do not pack the void around or above the appliance with insulation materials such as mineral wool or vermiculite.

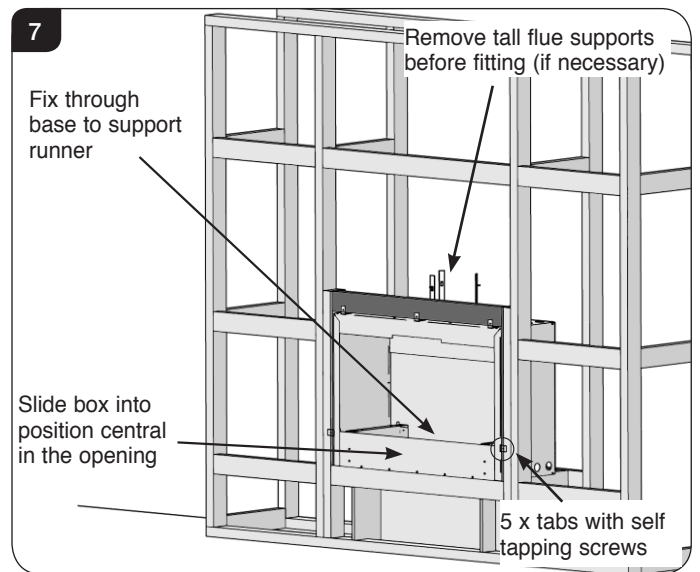

- 6.8 Fix the 12mm thick heat resistant board in position in the 3 areas shown, see Diagram 8.

Do not fit the lower section of the board as this will prevent the Studio Outer box from being installed.

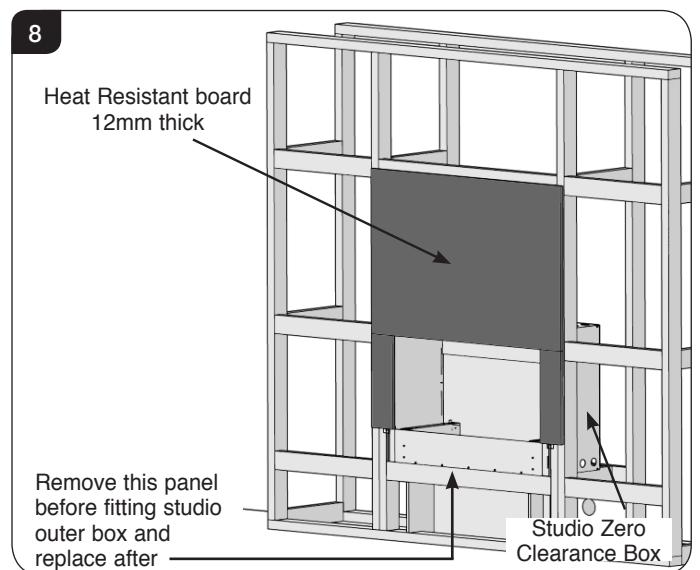

- 6.9 Remove the lower panel of the Zero Clearance Box and the flue collar from the Studio outer box.

Installation Instructions - Zero Clearance Box

Separate the inner and outer boxes, see Pre-Installation Section 5d Page 17.

Fit the Studio Outer Box in (with brackets or edge Kit Included) position in the Zero Clearance Box.

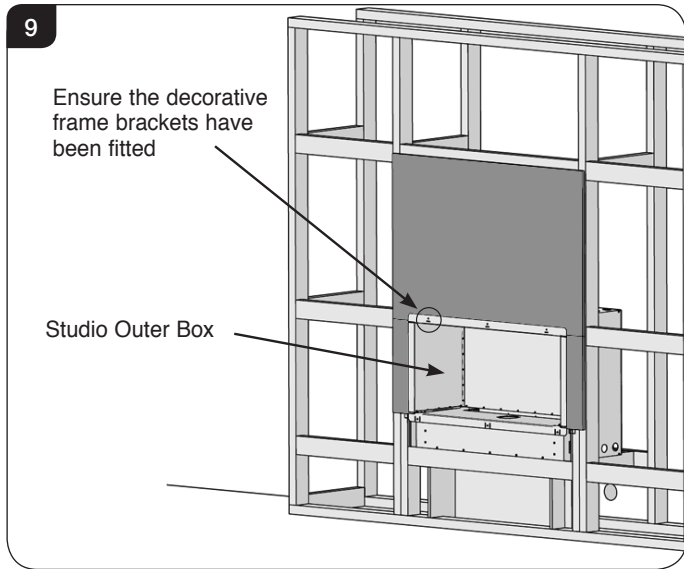

NOTE: The fixing brackets for the decorative frame must be fitted to the outer box before installing into the Zero Clearance Box, see Installation Section 3. The brackets can not be fitted after the outer box has been installed.

Alternatively if an Edge finish is required ensure that the frame is fitted before installing into the Zero Clearance Box, see Installation Section 3. The frame can not be fitted after the outer box has been installed.

Ensure the Outer Box is positioned centrally and replace the lower panel.

- 6.10 **If installing a rigid fluepipe system replace the flue collar in the outer box.**
The chimney/flue must have a sealed connection to the appliance flue spigot.

7. Flue Assembly

Rigid Flue System

- 7.1 It is recommended that this appliance is used in conjunction with a triple wall flue system as per the manufacturers requirements and AS/NZ 2918:2001 ensuring the centre and outer skins are supported on the box brackets to maintain the required clearances from the box, see Diagram 10.

Attach the rigid flue system or the flue liner can now be lowered through the outer box and connected to the outer flue collar using a suitable adapter. Make sure that these joints are secured using suitable stainless steel fasteners and sealed with fire cement.

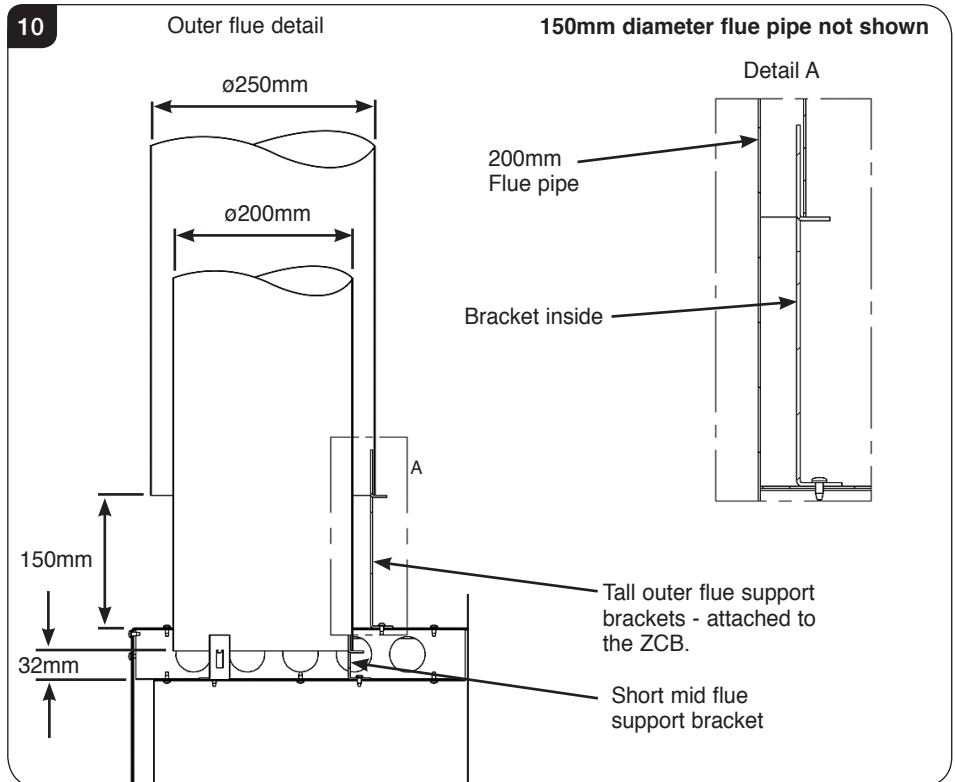

Installation Instructions - Zero Clearance Box

8. Finishing the installation

- 8.1 Fit the lower heat resistant panel ensuring it slides into position behind the flange of the Studio Outer Box. Fix the outer firebox to the Zero Clearance Box runners using 2 x self tapping screws - one on each side. Ensure the screws are 10mm clear of the inner box guides, see Diagram 11.

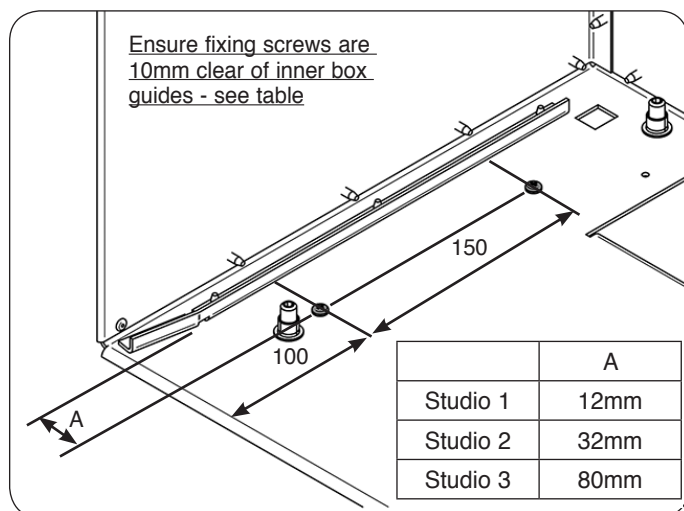
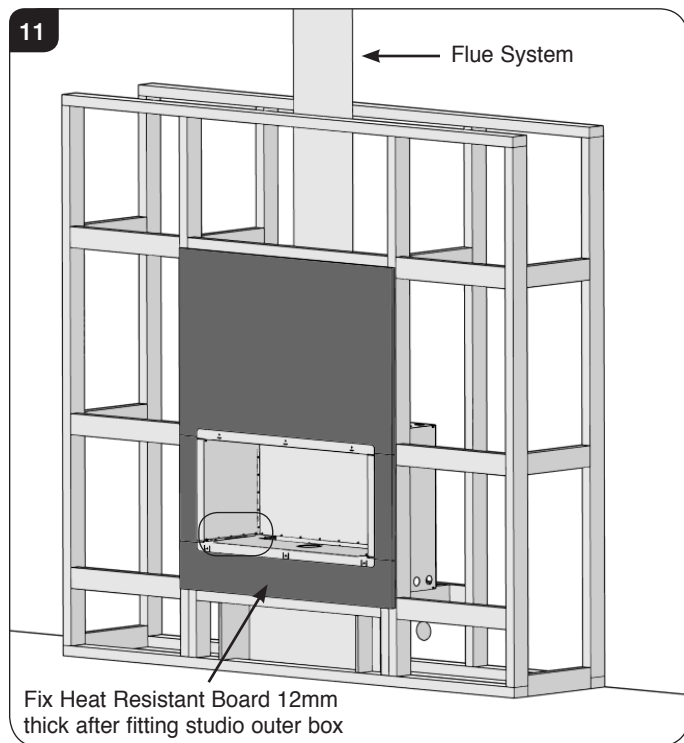

- 8.2 Fix and finish the remaining wall panels.

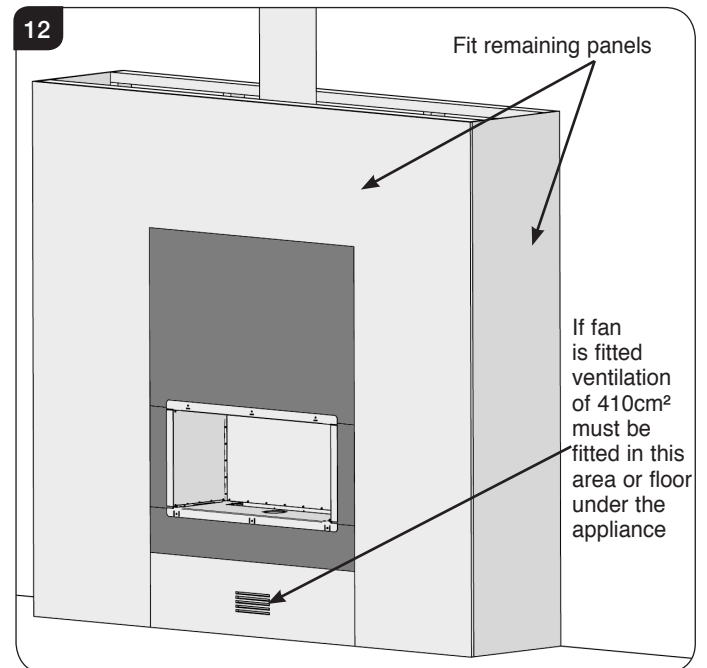

If a convection fan is to be fitted, leave a convection hole in the lower panel below the front of the opening. This hole must have a minimum free area of 410cm².

- 8.3 Apply a heat resistant plaster finish to at least 900mm above and 400mm to the sides of the chimney breast.
- 8.4 The inner flue collar, firebox can now be installed, see Section 13 Page 34 and the frame fitted.
- 8.5 Commission the appliance once installation is complete, see Page 38.

Installation Instructions - Zero Clearance Box

9. Studio Edge Frame Installation

There is an optional Studio Edge Installation Kit designed to create a minimalist frameless finish making the appliance a focal point of any room:
 Studio 1 Code No. RVS-1FEK,
 Studio 2 Code No. RVS-2FEK,
 Studio 3 Code No. RVS-3FEK.

The Edge installation kit is provided unfinished. This allows the kit to be finished to match the front face decor by applying a heat resistant paint. Stovax Riva Midnight Black is recommended.

- 9.1 Fit the Edge frame to the outer box prior to installation the frame out construction.
- 9.2 Build the frame out chimney breast as described in Section 5 **BUT ensure that the platform, lintel and inner frame out for the appliance is recessed 'X' mm back from the front edge of the main frame out**, see Diagram 13.

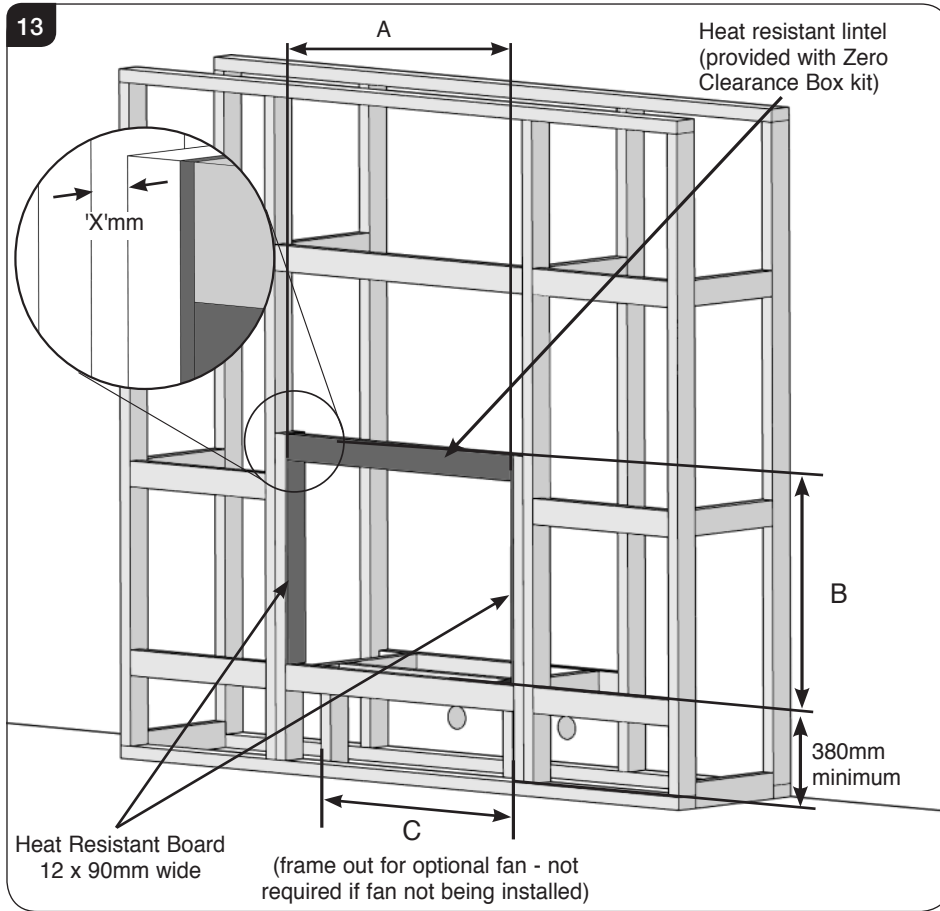

To calculate 'X':

- Studio 2 = 34mm - final Board/Coat
- Studio 3 = 44.5mm - final Board/Coat

Typical final Board/Coat would equal 12mm Board + 3mm Coat = 15mm.

Model	A	B	C
Studio 1	830	689	605
Studio 2	1030	712	750
Studio 3	1417	723	1300

Installation Instructions - Zero Clearance Box

- 9.3 Locate the appliance on the platform.
- 9.4 Fit Heat Resistant Board (Supalux or similar) into the recess around the outer box.
- Ensure all clearances to heat sensitive material are maintained.

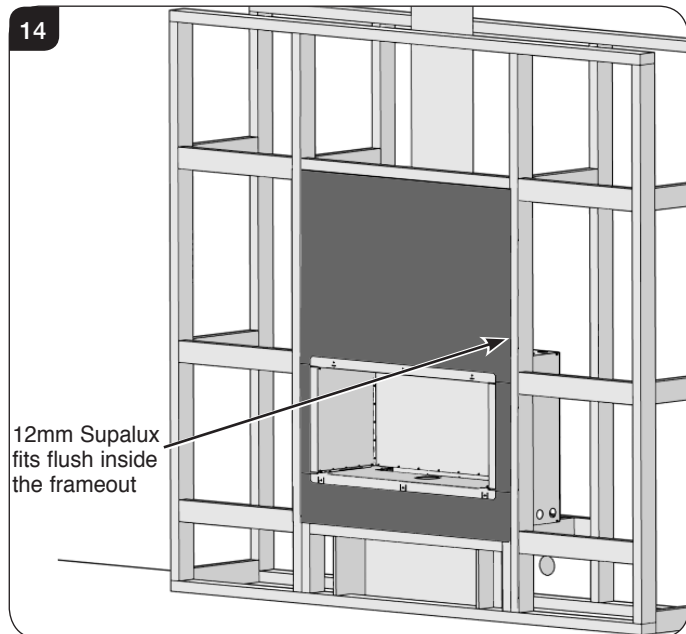

- 9.5 Fit another layer of Heat Resistant Board to the highlighted area ensuring it is at least 400mm to the sides and 900mm above the appliance. Fit the plasterboard to the remaining frame out, see Diagram 15.

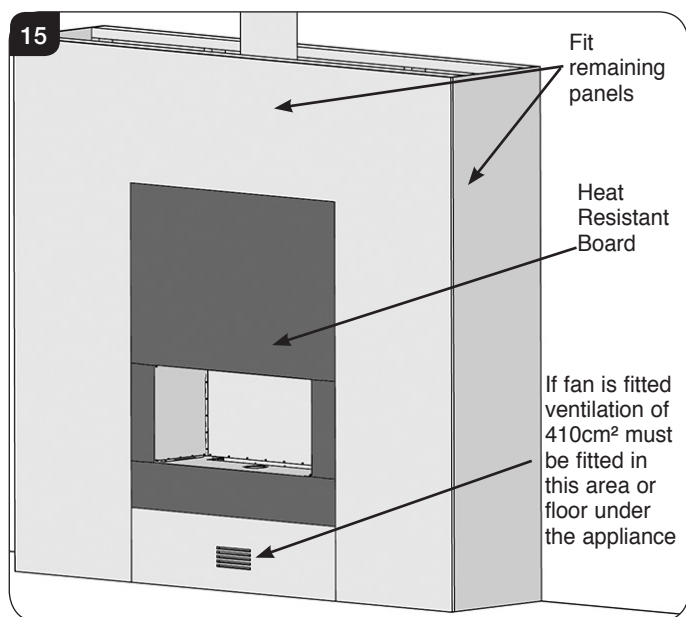

- 9.6 Apply a heat resistant plaster finish to **at least 900mm above and 400mm to the sides of the chimney breast**, making sure it is not too thin or it will crack, see Diagram 16.

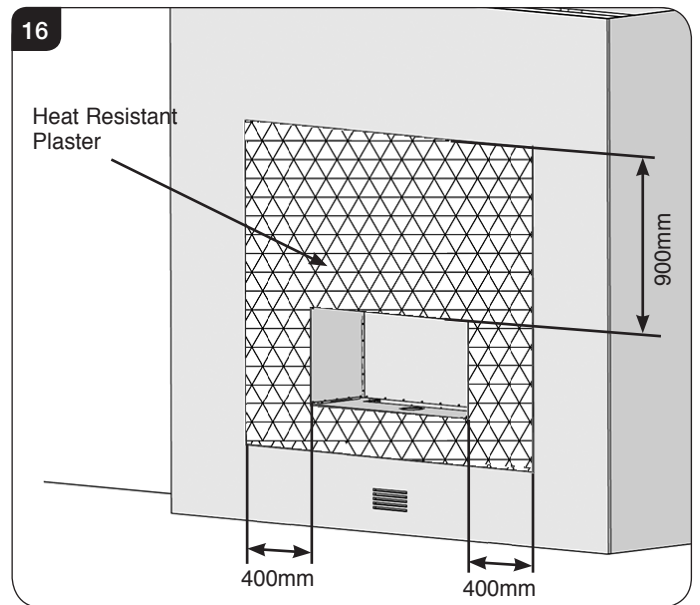

- 9.7 Allow for the connection of the following:
- Electrical services (for fan installation) using the opening in the side of the chimney breast for access.
 - The flue system (see Installation Section 7 Flue Assembly).
- 9.8 To finish this installation re-install the inner box, see Installation Section 13 Page 34 and finish the sides of the frame out chimney breast.

Installation Instructions - Masonry

Masonry Installation

10. Builders Opening

The Stovax Studio models differ from Gas burning models and the clearance to heat sensitive materials is greatly different due to the higher temperatures that the appliance can reach. Extra care must be taken when creating a builders opening. Pay careful attention to the distance to heat sensitive materials recommended and ensure the housing for the appliance is built from heat resistant material.

To make installation easier make the opening slightly larger than the minimum requirements where possible.

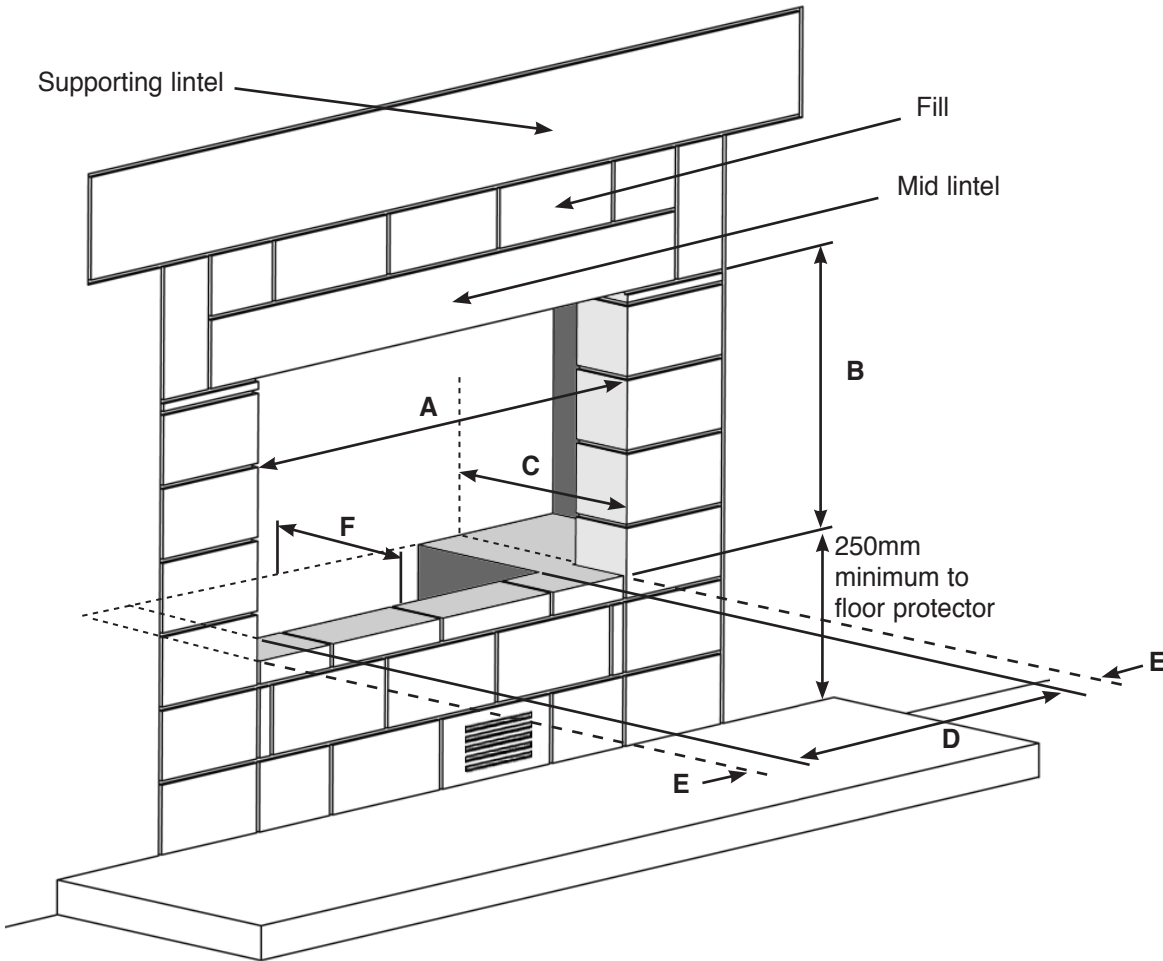

Many fireplace openings have a supporting lintel. Remove the covering plaster to identify its position before starting any constructive work. Do not remove constructional lintels without making provision to support the remaining structure of the building. The appliance must not form any part of the supporting structure.

Dimension	A	B	C	D	E	F*
Studio 1	765	435	360	615	75	100
Studio 2	970	460	360	820	75	100
Studio 3	1352	475	405	1202	75	100

- 10.1 The chimney/flue must have a sealed connection to the appliance flue spigot.
- 10.2 The structure of the builders opening will reach high temperatures. Use insulating blockwork to reduce the heat transfer to the external walls.

Ensure opening is built to meet relevant Local Building Codes.

* Minimum

Installation Instructions - Masonry

11. Build Enclosure

11.1 Fireplace openings usually have a supporting lintel. Do not remove without supporting the remaining structure of the building. **Do not support the masonry structure with the appliance or the flue system.**

11.2 You will need to create an opening and recess with the dimensions shown in the builders opening table in Section 10.

11.3 **NOTE – It is important to:**

- Support the base of the appliance as shown in the diagram on page 30 leaving the space in the middle for the fan housing (this is needed even if the fan is not fitted). Make sure that this surface is level.
- Fill any gap between the lintel above the appliance and the supporting lintel. This is important to protect the wall from the heat of the flue liner.
- Provide a solid back to the fireplace opening as it is necessary to bolt the back of the appliance to the wall. Build out the opening with additional masonry as required.
- **If the optional fan kit is to be fitted then provision must be made for the provision of 410cm² ventilation at the front and the electrical connection prior to fitting the appliance.**



NOTE: The fixing brackets for the decorative frames must be fitted to the outer box, before installation, see Installation Section 3. The brackets can not be fitted after the outer box has been installed.

Alternatively if an Edge finish is required ensure that the frame is fitted to the outer box before installation, see Installation Section 3. The Edge kit can not be fit after the outer box has been installed.

- Test install the outer case of the appliance, checking that when the plaster is applied to the front of the wall the outer flange will sit flat against the wall.
- When certain that the outer case will correctly fit the recess that has been made, and will sit level and flush against the wall, apply the final finish to the front face of the fireplace.
- **Take care when finishing the chimney breast and surrounding area. The conducted and convected heat emitted by the appliance could be high enough to crack normal plaster. Use a high temperature plaster, or face the area with a suitable high temperature heat resistant board avoiding any joints above the appliance. New plaster should be fully dried before the appliance is used, or cracking could occur.**

Stovax recommend the use of a flue liner when installing into a masonry chimney. Alternative methods can be used if the chimney is sound and correctly sized, however access may be required to make an effective seal - ie Using a sump adapter.

Important Note: If you plan to install an optional fan kit preparation must be made for the installation of wiring and sockets.

Installation Instructions - Masonry

Removal of Outer Collar

11.4 If fitting a flue liner to a pre-existing chimney it will be necessary to remove the outer collar to attach the liner.

11.5 Separate the inner and outer boxes, see page 9.

If access allows the installation of a rigid flue system this is not required.

11.6 Using a 13 A/F Spanner remove the 3 x bolts and remove outer collar, see Diagram 17.

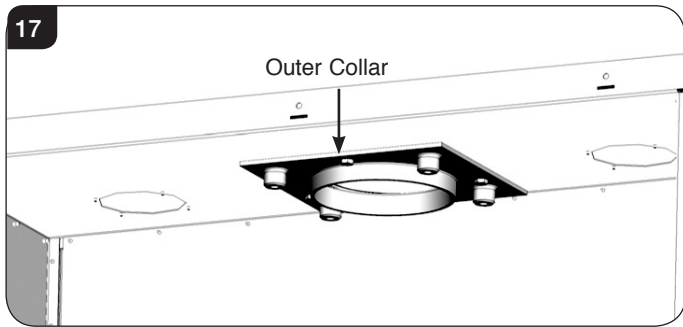

11.7 There is a Flue Collar Bracket on top of the Outer Box. This locates on two pins that allow flexibility when replacing the Outer Collar. The bracket remain in place when installing the flue system, see Diagram 18.

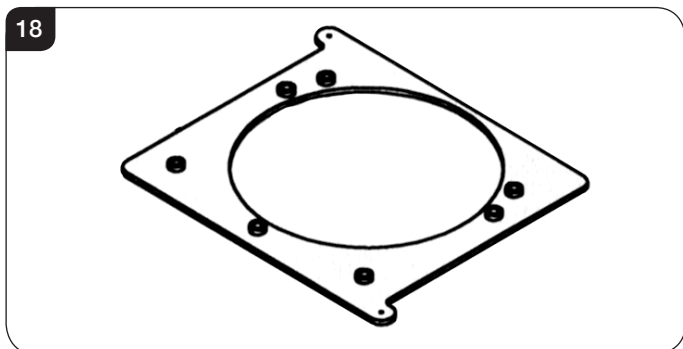

11.8 If the optional fan is to be fitted, remove the fan cover in the base of the outer case. This cannot be removed after the outer case has been installed. Full instructions are included with the fan (PM379).

Fit frame fixing brackets or Edge frame kit as required. See alternative frame instructions (PM378) for individual fixing methods.

11.9 The outer box can be slid into the chimney opening and fitted.

11.10 The position of the box can now be improved within the builder's opening by adjusting the four levelling feet to ensure it sits firm and level at all four corners, see Diagram 19.

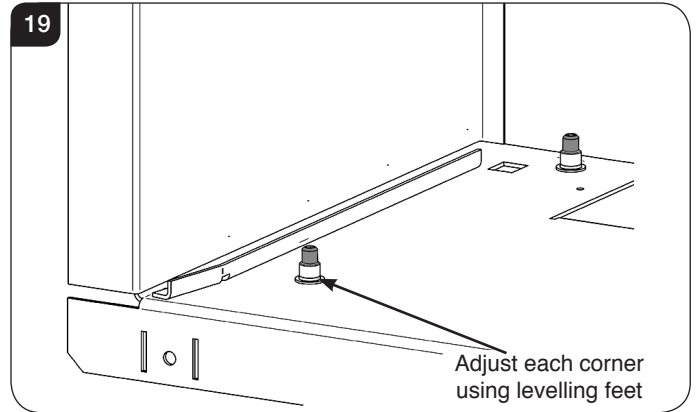

11.11 Wind the set screws down to the desired position in each corner.

THIS APPLIANCE MUST BE SECURELY BOLTED IN POSITION TO SUPPORT THE DOOR WHEN IT IS OPENED.

Use M6 or M8 bolts to secure the outer case to the masonry of the fireplace. There must be at least two bolts in the back of the outer case and one in either side. These can be secured through the side or base of the outer case (see shaded area in Diagram 20). Check the security of these fasteners before proceeding to fit the inner box.

The fixing above must also comply with AS/NZ 2918:2001 Section 3.8 for seismic restraint. Earthquake restraints may be positioned by drilling though the firebox into the base of the outer box and fixing within the shaded area shown in Diagram 20 using 2 x M8 bolts or similar. Do not over tighten and deform the firebox.

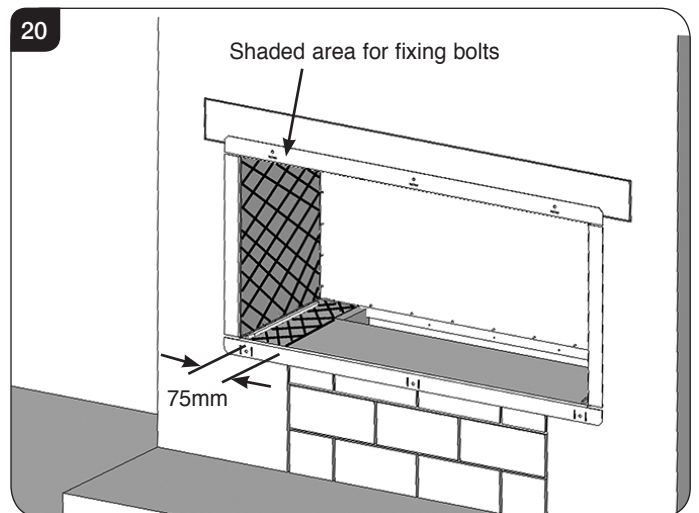

Installation Instructions - Masonry

11.12 Attach the rigid flue system or the flue liner can now be lowered through the outer box and connected to the outer flue collar using a suitable adaptor. Make sure that these joints are secured using suitable stainless steel fasteners and sealed with fire cement.

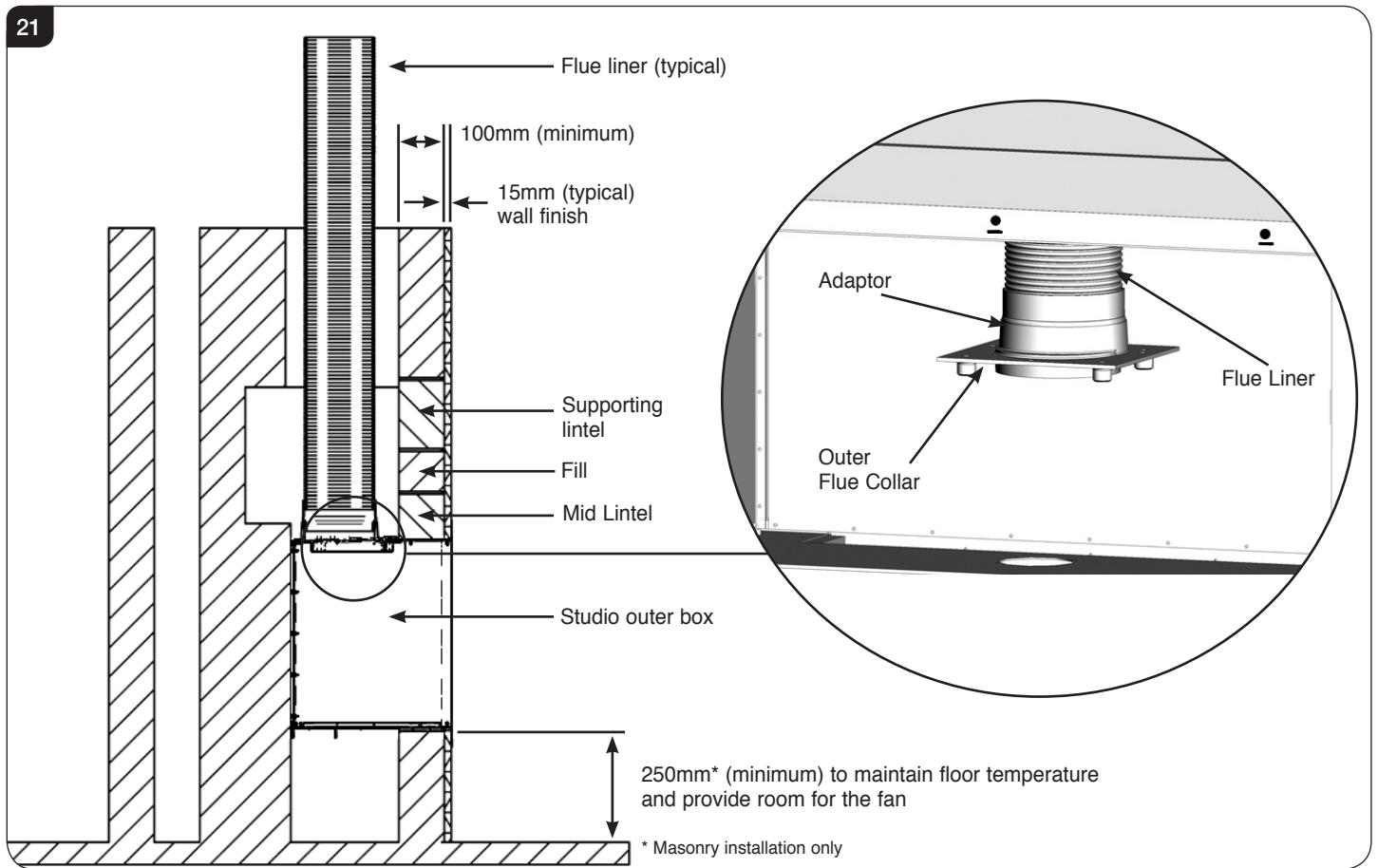

12. Fitting the Flue Collar - All Installations

If the outer flue cover has been removed it will be necessary to check the fit to avoid damage when refitting the inner box.

12.1 Replace the outer flue cover ensuring it clears the screws at the rear of the box. Secure the outer collar to the top of the outer case using the 3 x bolts, ensuring they are finger tight only, see Diagram 22.

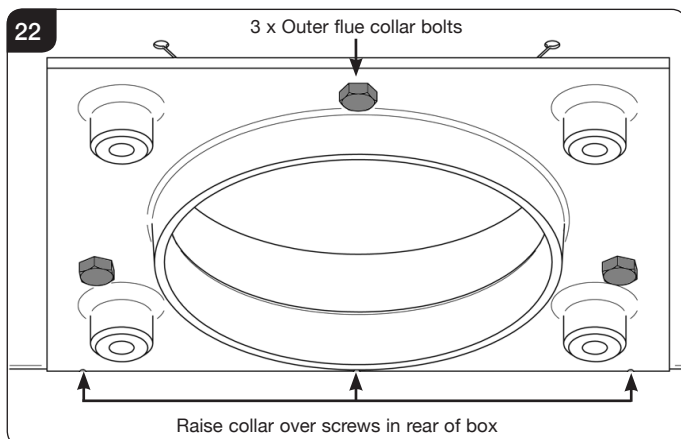

12.2 To ensure the outer collar is central, and to **avoid cross threading of the bolts** during actual installation, feed the 4 x bolts used to secure the inner collar into the holes in the outer collar as shown in Diagram 23. This should be done by hand and the bolts should be finger tight only. Do not force the bolts. If they are not easily located remove them and loosen the 3 x bolts holding the outer collar to allow for adjustment.

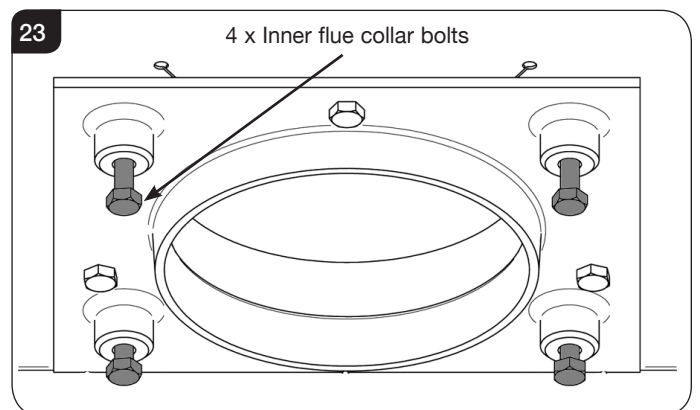

Installation Instructions

- 12.3 Once the 4 x bolts have been successfully located in the holes tighten the 3 x bolts securing the outer collar in place to create a good seal. **Do not over tighten the bolts.**
- 12.4 Remove the 4 x bolts and put them to one side until needed.
- NOTE: The flue system must be supported in accordance with the manufacturers instructions, there should be no weight on the Outer Box.**
- 12.5 Complete all decorative finishes before installing the inner firebox.
- 12.6 The inner firebox can now be installed, see Section 13 and the frame fitted.
- 12.7 Commission the appliance once installation is complete, see Page 38.

13. Installation of the Inner Box

NOTE: This will require 2 people.

- 13.1 Slide the inner box into the outer box. **There is a roller assembly at the rear of the inner box which locates in cutouts in the base of the outer box, see Diagram 24.**

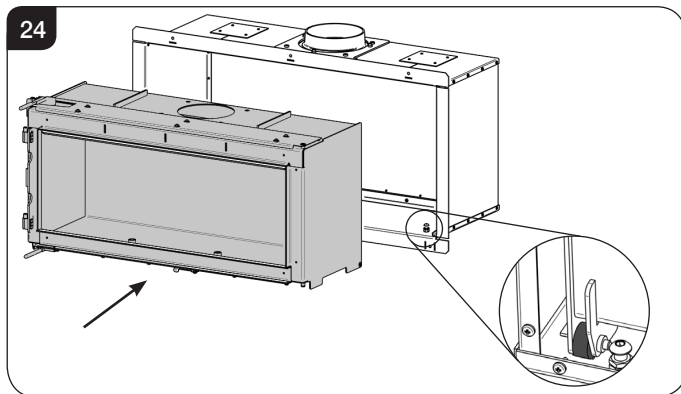

This will require 2 people.

- 13.2 Apply fire cement in to the faces shown in Diagram 25 prior to fitting the inner collar.

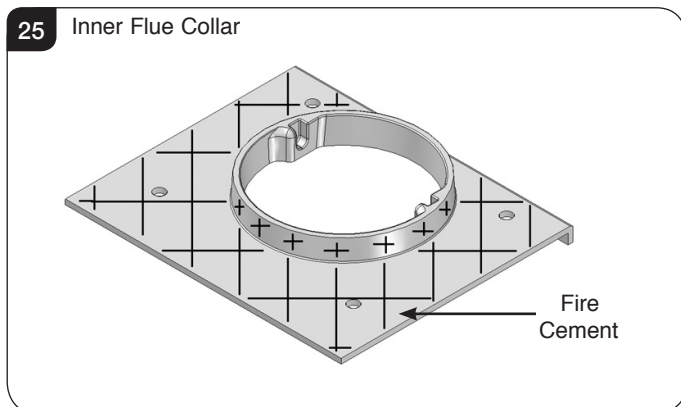

- 13.3 Fit the inner flue collar using the 4 x bolts ensuring the top hat spacers are replaced on the 2 x longer front bolts, see Diagram 26 and all bolts are finger tight only.

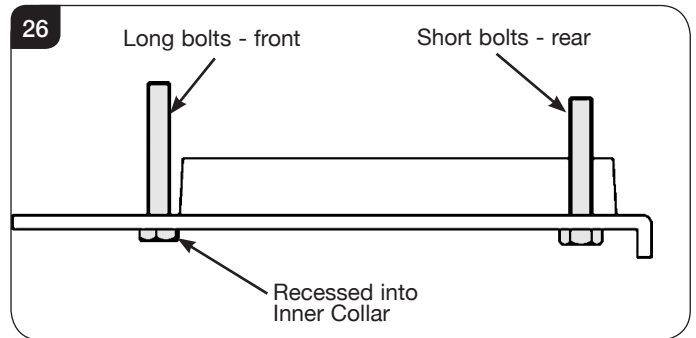

- 13.4 Ensure that the front of the inner box is parallel to the outer box, see Diagram 27. Adjust the position until correct and then fully tighten the 4 x bolts. Do not over tighten.

NOTE: When correctly installed the inner box sits parallel and proud of the outer box, see Diagram 27.

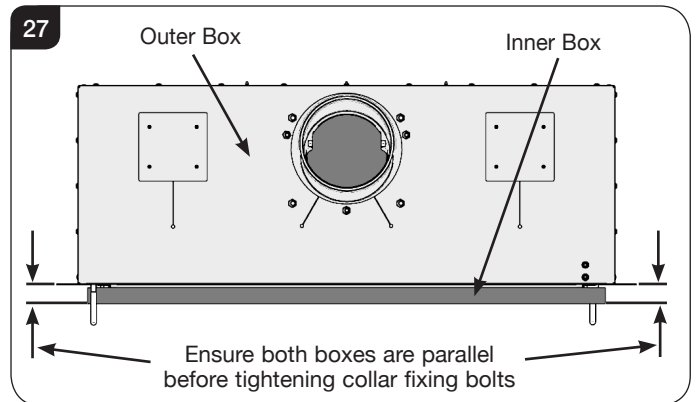

- 13.5 Fit the internal components following the Fitting of Internal Components Section 14.

- 13.6 Refit the door following the reverse of the process in the Pre-Installation section.

14. Fitting of Internal Components

Once the inner box has been installed the internal components can be fitted.

- 14.1 **The firebricks must be fitted before the baffle components.**

Firebricks

- 14.2 The Firebricks and Lower Baffle bricks are supplied in a box for safe transportation. It is advisable to carefully remove all of the bricks from the container in order to correctly identify the various types.
- 14.3 The side bricks have part of the Log bar supports attached. These must be fitted and removed at the same time as the bricks.

Installation Instructions

14.4 Install in the following order, see Diagram 28.

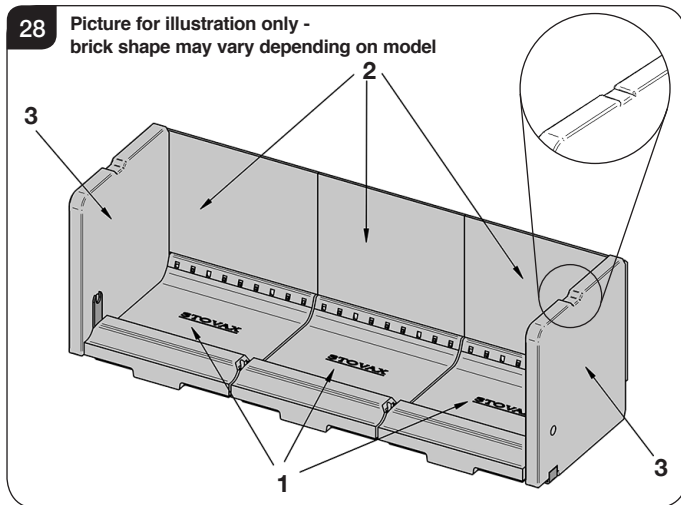

CAUTION: USE TWO HANDS WHEN FITTING THE FIREBRICKS.
Avoid placing uneven pressure on the bricks by using both hands and take care not to force into position.

14.5 To do this:

All Models

- Place the base bricks in the firebox (1). Fit the left and right hand base bricks, then the middle.
- Place the back bricks in position on top of the base bricks (2).
- Fit the side bricks (3) with the Log Guard Supports in place. The Log Bar Support holes can be used as a finger hold - follow the method for the relevant model.

Studio 1

Tilt the brick at an angle and feed the top edge up and into the gap at the top of the firebox.

Straighten the brick in this position and lower into the gap between the side of the inner box and the base brick ensuring the Log Bar Support remains in place, see Diagram 29 and 30.

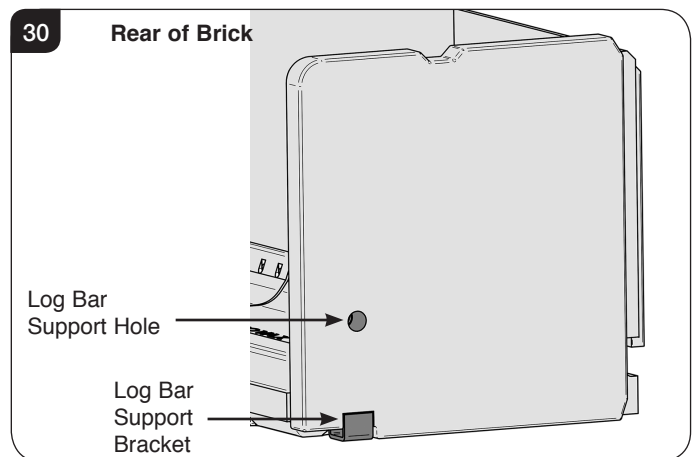
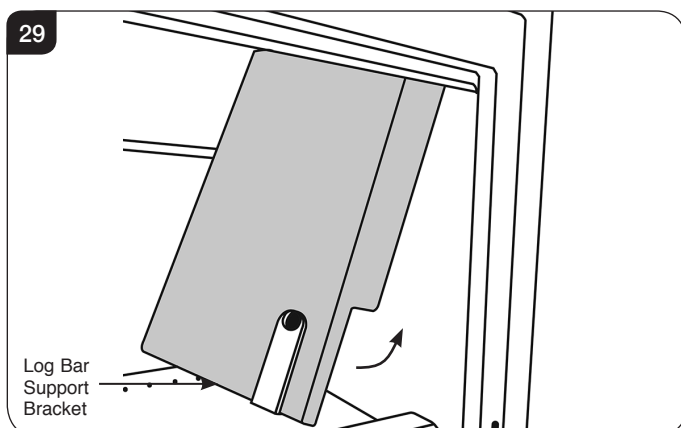

Studio 2 & 3

Tilt the brick at an angle and feed the lower edge down into the gap between the base brick and the side of the inner box.

Straighten the brick in this position and drop into place ensuring the Log Bar Support remains in place, see Diagram 30 and 31.

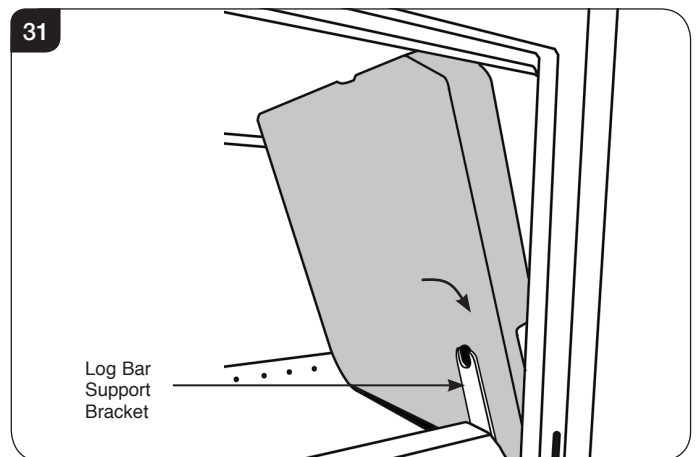

14.6 Removal is the reverse of this procedure. Allow the appliance to cool fully before removing baffle system.

Do not modify firebricks.
Do not operate with firebricks removed.

Installation Instructions

Upper Metal Baffle

The appliance is fitted with baffles in the top of the firebox to maintain efficient combustion.

Studio 1 has 1 baffle.

Studio 2 has 2 baffles.

Studio 3 has 3 baffles.

See Pre-Installation section, Page 8 for details.

All Models

- 14.7 Use two hands and place the rear edge of the baffle over the support pins at the back of the firebox. Raise the front so it is level and pull the baffle forwards to the front of the appliance and locate the keyslots in the front lip over the tabs at the top of the inner box, see Diagram 32.

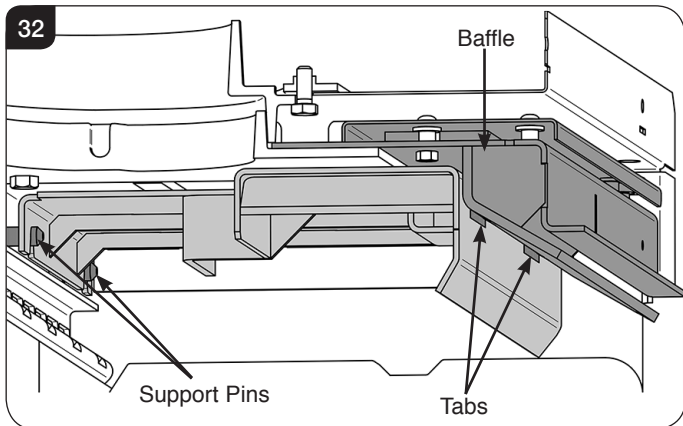

- 14.8 The baffle system is designed to give safe and efficient operation of the stove. Replace damaged baffles immediately.
- 14.9 **Do not modify the baffle system.**
Do not operate with the baffle system removed.

Lower Baffle bricks

The appliance is fitted with baffles in the top of the firebox to maintain efficient combustion.

- 14.10 To fit the Lower Baffle Bricks feed the Front Baffle Support bar into the appliance and rest on top of the side bricks. This is best done by feeding one end of the bar towards the back of the firebox at an angle and then inserting the other end.
- 14.11 Once the support bar is inside the firebox bring forward as far as possible and place on the side bricks with the solid edge facing forward.
- 14.12 Insert the baffle bricks (see table) ensuring they are in the correct orientation, see Diagram 33.

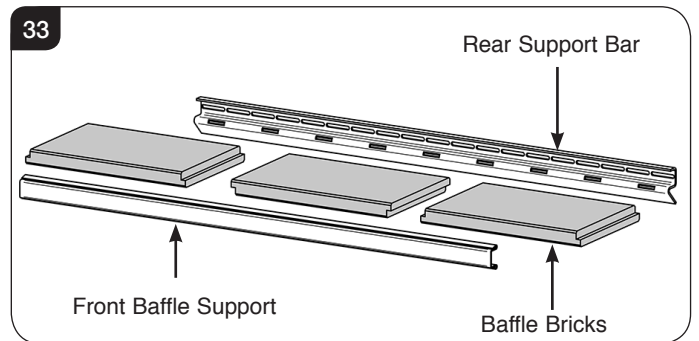

Model	Baffle Number
Studio 1	3
Studio 2	3
Studio 3	4

- 14.13 To do this:
- Rest the rear edge of the bricks on the support bar at the back of the firebox.
 - Fit the two side bricks first, then insert the middle brick and support.
 - Fit the Front Baffle Support over the front edge of the baffle bricks to hold in place.
 - The Front Baffle Support.

Do not modify baffle bricks.
Do not operate with baffle bricks removed.

Installation Instructions

Log Guard

14.14 Ensure that the side supports have been fitted at the same time as the side Firebricks

To fit the Log guard:

- Insert the Log Guard through the front of the appliance at an angle and rotate.
- With one end raised place the other end into one of the holes in the side bricks.
- Lower the Log Guard and insert the supports into the gaps between the base bricks and into the retaining brackets, see Diagram 34.

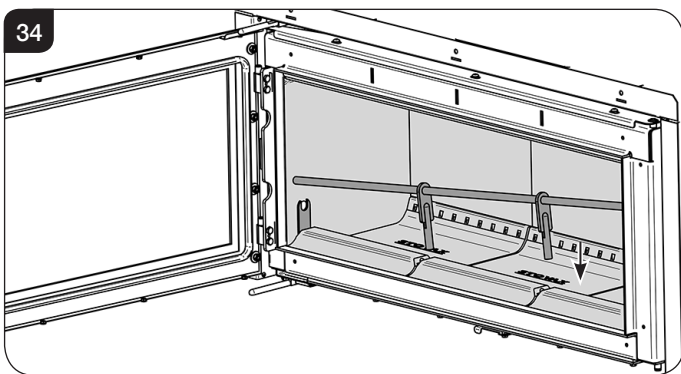

- Slide the Log Guard across so both end locate evenly in the holes in the side bricks, See Diagram 35.

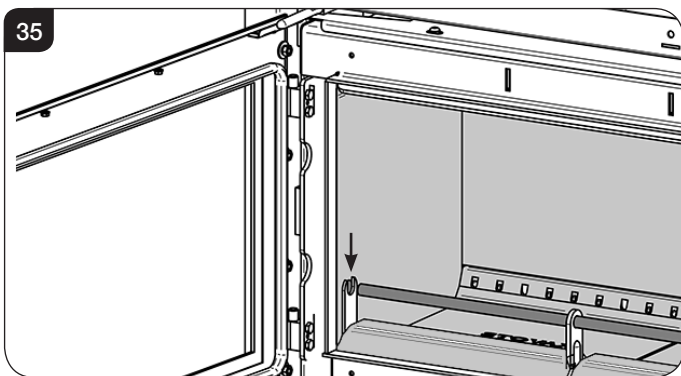

Do not use appliance without the log guard in position.

15. Alarms

15.1 All open flued appliances can be affected by temporary atmospheric conditions which may allow fumes to enter the house. **It is recommended that whenever a new or replacement fixed solid fuel or wood/biomass appliance is installed in a dwelling a carbon monoxide alarm be fitted in the same room as the appliance.**

Provision of an alarm must not be considered a substitute for either installing the appliance correctly or ensuring regular servicing and maintenance of the appliance and chimney system.

15.2 It is mandatory for a Smoke Alarm to be fitted into the room with the appliance.

16. Smoking Fires (Smoke spilling back into room)

Modern home constructions can be extremely airtight and it is vital that Replacement Air (internal air consumed by the fire for combustion and flued to the atmosphere) is provided.

These instructions allow for Passive Air Vents to the outside in order to provide Replacement Air by a natural thermal action from burnt gases leaving through the flue.

There are a number of appliances that may be contained within a home that can also contribute to internal air being removed (ceiling fans, extractor fans, washer/dryers etc). This leads to negative internal air pressure and can be one of the prime causes of smoke spilling back into the room when the doors are opened for refuelling.

In these cases Active Air Replacement is necessary to combat this internal pressure difference.

For more details see the Technical Specifications and the additional section on Ventilation - Page 47 & 48.

Commissioning

1. Commissioning

1.1 To commission:

- Ensure all internal components (log guard, baffle(s), bricks) are correctly fitted.
- Check the door alignment and catch operation, adjust if required (see Maintenance and Servicing).
- Check the soundness of door seals, castings and flue connections.
- Check the operation of the air control.

1.2 Now carry out a final smoke draw test:

- First warm the flue with a blowlamp, or similar, for about 10 minutes.
- Place a smoke pellet on the centre of the base bricks, with the air controls open.
- Close the door. Smoke should now be drawn up the flue and be seen to exit from the flue terminal.
- Complete test with all doors and windows closed in the room where the appliance is fitted.
- If there are any extractor fans in adjacent rooms, the test must be repeated with the fans running on maximum and interconnecting doors open.
- Check the effect of ceiling fans during the test.

If the test fails, re-check the suitability of the flue system and ventilation. **An inadequate air supply to the room is potentially dangerous.**

- Light the appliance and slowly increase the temperature to normal operating levels.
- Ensure no combustion products enter the room.
- Open the main fire door when the appliance reaches normal operating levels and carry out a spillage test with a smoke match or pellet around the door opening.

1.3 If excessive spillage occurs:

- Allow the appliance to cool and re-check the flue system and ventilation.

1.4 Finally:

- **Explain the safe operation of the appliance and the use of the controls to the user and the importance of only using suitable fuels.**
- **Explain the cleaning and routine maintenance requirements.**
- **Explain the requirement to use a suitable fireguard when children, elderly or infirm persons are near the appliance.**
- **Record dealer/supplier details and installer details on page 3 of this manual.**
- **Record serial number in page 3 of this manual.** This number is required when ordering spare parts and making warranty claims.
- **Give this instruction manual to the customer.**

Maintenance & Servicing

1. Annual Service

1.1 Before the start of the heating season strip, inspect and clean the appliance as detailed:

- Allow appliance to cool.
- Remove all internal parts: baffle(s), log guard and firebricks (*see Installation Instructions, Section 5, Page 7*). Take care handling firebricks as they can become fragile after a period of use.
- Sweep the appliance at this point if necessary.
- Vacuum clean any remaining ash and debris from the inside of the appliance. Stovax offer a filter/collection attachment for vacuum cleaners to protect them from fire ash: Ash Clean (Stovax Part No. 2091).
- Check the parts for any damage. Replace any damaged parts using genuine Stovax replacements parts.
- Check and clean the firebricks with a soft brush. Some surface damage will occur during use. The life of the bricks will depend on the type of fuels burnt and the level of use. **Replace damaged bricks as soon as possible.**
- **Do not use acidic cleaners on printed glass.**
- Re-fit cleaned internal parts.
- **Do not use cleaning agents that have a high alkaline content, for example Stovax Gel Cleaner, on appliances with painted glass. These are abrasive cleaning agents that are designed to be used with heavily stained clear glass. Use Stovax Glass Cleaner (Stovax No.4103) on more delicate surfaces.**

Do not use abrasive cleaners to remove tar or soot deposits from the glass.

- Fit new door rope seal (see Maintenance and Servicing, Section 4).
 - Lightly oil the door catch mechanism and hinge pins. Avoid getting oil onto the door seals and glass.
 - To refresh painted finishes use Stovax Riva Midnight black paint.
- 1.2 Burn at a low temperature for the first day of use after any maintenance. This allows the seals, fixing glues and paint to fully cure.
- 1.3 During this time the appliance may give off some unpleasant odours. Keep the room well ventilated to avoid a build-up of fumes.
- 1.4 Your Stovax dealer can carry out service and maintenance.

This is a list of the maintenance products that may need be required:

Task	Product name
Preventing build-up of creosote in flue	Protector (15 sachets)
	Protector (1kg tub)
Sealing flue pipe joints	Fire Cement (500g tub)
	Fire Cement (600g cartridge)
Re-painting	Riva Midnight Black (150ml aerosol)
Protecting your hands	Heat resistant leather gloves
Door sealing rope	16x10 Flat Rope Handy Pack
	Ø13 Rope Seal Handy Pack
	16x10 Flat Rope 25m Roll
	Ø13 Rope Deal 25m Roll
Thermic seal glue	(50ml bottle)
Ash Clean	Vacuum Cleaner Attachment
Door Maintenance (Studio 3 only)	Anti-Seize Grease

These products, available online at www.stovax.com or from your local Stovax dealer, along with regular maintenance and use of correct fuels, will keep the appliance in the best possible condition.

Maintenance & Servicing

2. Removal of Internal Parts

- 2.1 To service and maintain the good working condition of your appliance it will be necessary to remove several internal parts. Consult the Pre-installation and installation sections to remove the:

Door
Log Guard
Firebricks
Baffle Bricks
Upper Baffle
Flue Collar

3. Fitting a New Door Glass - All Models

- 3.1 To maintain safe use of your appliance you may need to replace a damaged door glass. A replacement glass panel can be ordered which will be supplied with full fitting instructions:

Studio 1 - RVS-CE7473
Studio 2 - RVS-CE7477
Studio 3 - CE7499

4. Fitting a new Door Seal - All Models

- 4.1 To maintain the safe use of your appliance you need to replace damaged or worn door sealing rope. To complete this operation remove the door see Section 5 Fitting & Removal of The Door in the Pre-Installation section.

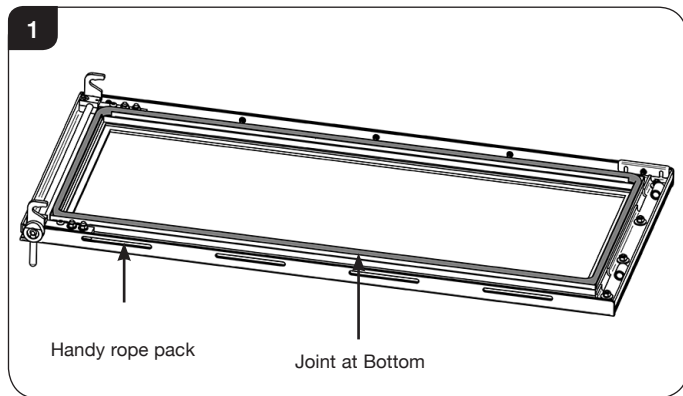

- 4.2 Remove the old rope and scrape old glue from the locating groove. Clean the locating groove with a clean dry cloth to remove all old dust and debris.
- 4.3 Squeeze a generous bead of fresh Stovax Thermic Seal glue into the rope locating groove.
- Press the new Stovax rope into the locating groove, placing the joint in the middle of the top edge of the door using tape supplied for the ends.
- 4.4 Refit the door and close the door to apply pressure to the new rope.

Leave the appliance closed for at least 12 hours before lighting the appliance and using at a low output for approximately one day.

- 4.5 Using the appliance with a damaged door seal can cause dangerous fumes to enter the room, or the appliance to over fire, resulting in damage.

5. Door Hinges

5A. Adjusting Door Hinges - Studio 1 & 2

- 5a.1 To maintain the safe use of your appliance, you may need to adjust the door hinges to ensure the safe, correct closing of the door. The door must be horizontal/level with the top of the inner box and the door catch engages correctly.
- 5a.2 Adjustment is possible in 2 places:
Door Hinge Assembly
Hinge Blocks on Inner Box
- 5a.3 Open the door to give access to these 2 positions.

Door Hinge Assembly

- 5a.4 Use a 10mm socket to slightly loosen the fixing nuts on the Door Hinge Assembly, see Diagram 2.

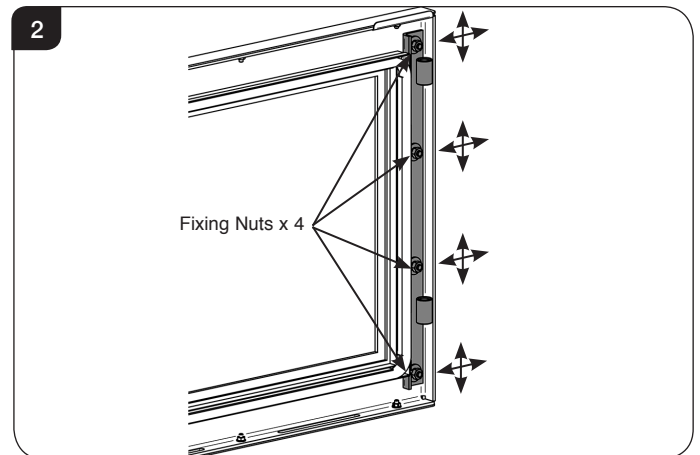

- 5a.5 Loosening the Door Hinge Assembly allows for fine vertical and horizontal adjustment of the door position. This may require a trial and error approach to find the correct position. Ensure the door is horizontal before tightening the fixing nuts.

Maintenance & Servicing

Hinge Blocks on Inner Box

- 5a.6 Using a 10mm A/F spanner slightly loosen the fixing nuts inside the stove as shown in Diagram 3. This will give vertical and horizontal adjustment which may need a trial and error approach to find the correct position. The door must be horizontally level.

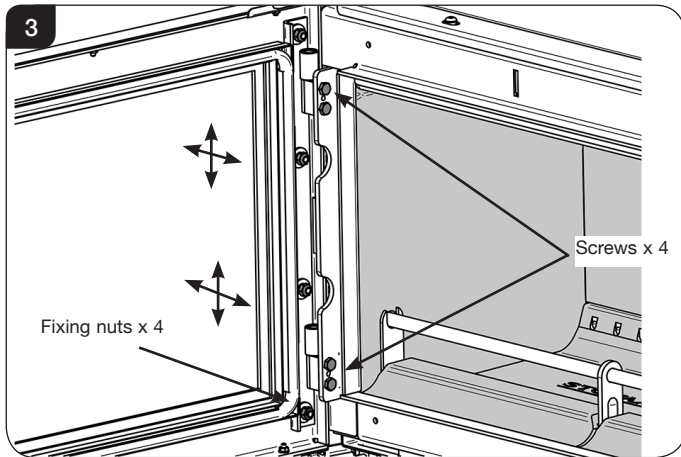

5B. Lubricating Door Hinges - Studio 3 only

- 5b.1 If the operation of the door becomes stiff or fails to close properly it may be necessary to apply grease to the door hinge.
- 5b.2 Complete lubrication of the hinges as follows:
- Open the door fully.
 - Use a small paint brush to add a small amount of high temperature anti-seize grease (Stovax part number - RVS-MEC10275) to points 'A' and 'B', see Diagram 4.

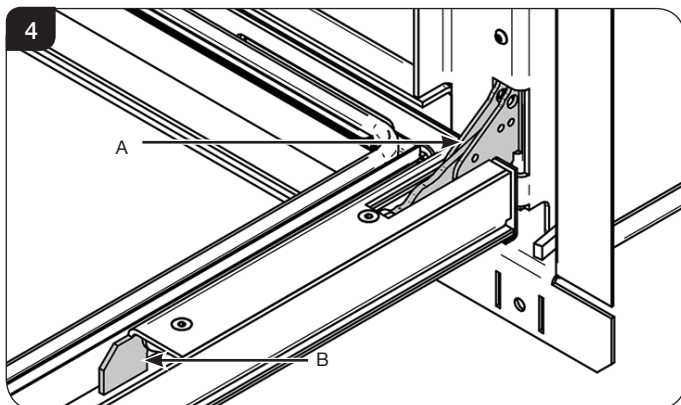

- 5b.3 Open and close the door a few times to work the grease into the hinge to return it to smooth operation.

6. Door Catch

6A. Adjusting the Door Catch - Studio 1 & 2

- 6a.1 To maintain the safe use of your appliance you may need to adjust the door catch to ensure the safe, correct closing of the door. If the door hinges have been adjusted the door catch may need adjustment.
- 6a.2 The catches are located at the top and the bottom of the right side of the door.

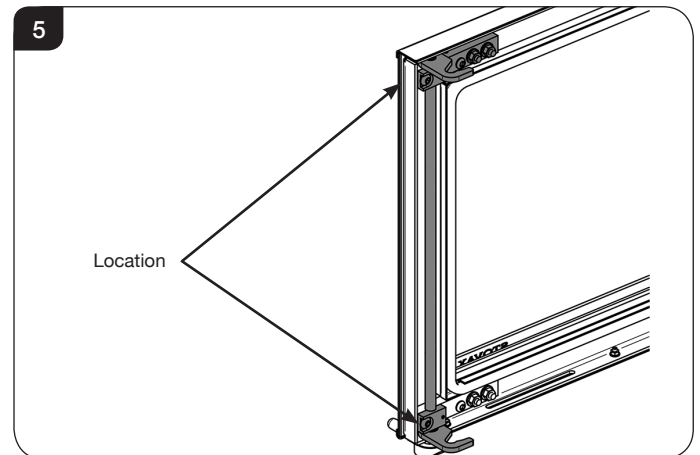

- 6a.3 The top and bottom catches will need to be adjusted separately and in the same manner. The catch block can move in two directions, see Diagram 6, 7 & 8.

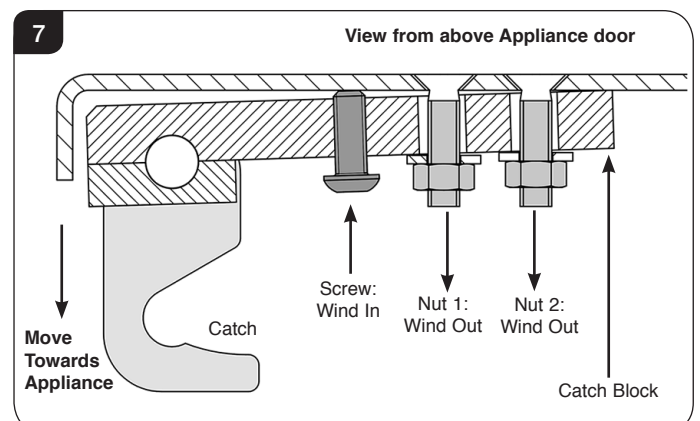
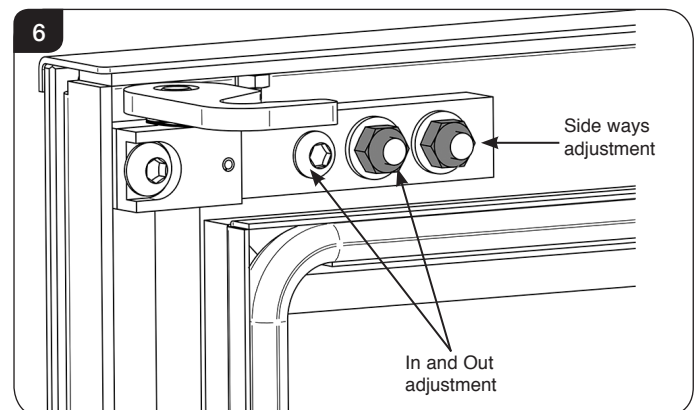

Maintenance & Servicing

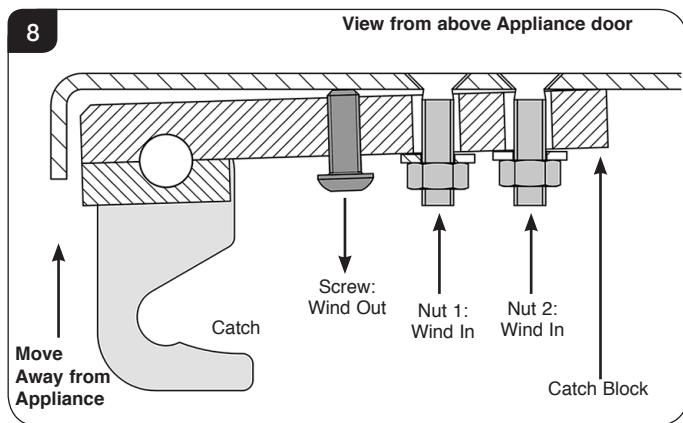

Sideways Adjustment

Using a 10mm A/F Spanner loosen the 2 nuts that hold the catch block to the door.

Do not remove the nuts completely.

This will allow some movement left or right to suit.

Tighten the nuts and recheck the catch operation.

In and Out Adjustment

Loosening or tightening the M6 screw and the nuts on the catch block will cause the catch to move in or out from the door and allow the hook to gain better purchase on the door rollers.

Do not remove screw or nuts completely.

6a.4 To move Door Catch in:

Loosen Nuts 1 & 2.
Wind screw **IN** until the Door Catch is in desired position.
Tighten Nuts 1 & 2 down to Catch Block.

6a.5 To move Door Catch out:

Loosen Nuts 1 & 2.
Wind screw **OUT** until the Door Catch is in desired position.
Tighten Nuts 1 & 2 down to Catch Block.

Do a Paper Test

To do a paper test shut a piece of paper in the door at the edges to test how well the rope seal stops the air from entering the appliance. If the paper can be pulled out easily then the seal is not sufficient and the rope must be replaced.
Repeat this around all the edges of the stove.

6B. Adjusting the Door Catch - Studio 3

6b.1 There is no user adjustment of the door.

7. Removal of the Firebricks

Depending on the model purchased it may be necessary to remove additional parts of the appliance when servicing to access the firebricks.

Studio 1

It is possible to remove the firebricks with the Upper Metal Baffle in place.

Remove the following:

Log Guard

- Slide the Log Guard to one side to disengage from the hole in the side brick.
- Raise the free end and remove from the gaps in the base bricks.
- Withdraw from the hole in the other side brick and rotate the Log Guard through the front of the appliance.

Baffle Bricks

Pull the Front Baffle Support off the baffle bricks and move as far forward as possible.
Carefully remove the bricks working from the centre outwards.

Angle the Front Baffle Support to free from the firebox.

It is now possible to remove the Firebricks.
Lift the side bricks using the Log Guard support slots as finger holds and clear the base bricks; angle the bottom of the side brick towards centre of the firebox and withdraw.

Remove the back bricks, then the base bricks.

Studio 2 & 3

It is necessary to remove the Baffle Bricks and the side Upper Metal Baffles before attempting to remove the firebricks to avoid damage, see *Pre-Installation Section* in the main instruction manual.

Lift the side bricks slightly using the Log Guard support slots as finger holds; tilt the top of the side brick towards centre of the firebox and continue lifting to withdraw.

Remove the back bricks, then the base bricks.

Technical Appendix

1. Legal Requirements

Before installation and/or use of this appliance please read these instructions carefully to ensure that all requirements are fully understood.

The appliance must be fitted by a registered installer*, or approved by your local building control officer.

It is very important to understand the requirements of the national Building Regulations and standards, along with any local regulations and working practices that may apply. Should any conflict occur between these instructions and these regulations then the regulations must apply.

Your local Building Control Office can advise regarding the requirements of the regulations.

Works must be carried out with care to meet the requirements of Health and Safety and comply with the Health and Safety rules, and any new regulations introduced during the lifetime of these instructions. Particular attention should be drawn to:

—Handling: The appliance is heavy. Adequate facilities must be available for loading, unloading and on site handling.

—Fire Cement: Some fire cement is caustic and must not come into contact with the skin. Protective gloves must be worn. Wash hands thoroughly with plenty of water after contact with skin.

—Asbestos: This appliance contains no asbestos. If there is the possibility of disturbing any asbestos in the course of installation seek specialist guidance and use appropriate equipment.

—Metal Parts: Take care when installing or servicing the stove to avoid personal injury.

A faulty installation can cause danger to the inhabitants and structure of the building.

For users of this appliance:

Your building insurance company may require you to inform them that a new heating appliance has been installed on your property. Check that your cover is still valid after installing the appliance.

DESIGN PROTECTION

The Studio design, including it's frames and accessories, are protected by European Design Registration
No. 001169338 0002 0008.

How to Obtain Warranty Service

How to Obtain Warranty Service:

All appliances must be installed according to the installation instructions provided, and meeting all local codes and regulations. Any service call related to improper installation, operator error, mis-use and environmental issues will not be covered under warranty with no exceptions.

It is essential that any appliance that is damaged in any way not be installed, and Regency notified of the extent of damage so the appropriate action can be taken to resolve the situation. Regency will not be accountable for any additional costs in the event of a damaged unit being installed.

The procedure required to submit warranty claims is listed below:

1. Customer shall contact the Selling Dealer with warranty claim with the warranty request.
2. The Selling Dealer will record the customer's details including names, address, contact numbers, the appliance type and brief description of problem.
3. Serial number should also be provided.
4. The Selling Dealer will complete a "Regency Request for Warranty Form" along with a copy of the customer sales order to verify date of purchase and forward this information to Regency Fireplace Products.
5. On receipt of warranty claim, Regency will process the claim and pass details on to the appropriate Technician.
6. Technician will contact the customer and make an appointment time.

Customers should not call Regency direct for warranty requests. Any such calls will be redirected back to the Selling Dealer so the above procedure can be followed.

Please note Fireplace Products Australia Pty Ltd does not provide installation services.

In Western Australia, the company below is responsible for all Warranty Requests & Services:

Air Group Australia
28 -30 Division St
Welshpool, W.A. 6106
Phone (08) 9350 2200 Fax (08) 9353 4225

Technical Appendix

2. Flue Outlet Positions

Minimum Flue Height as per AS/NZS 2918:2001

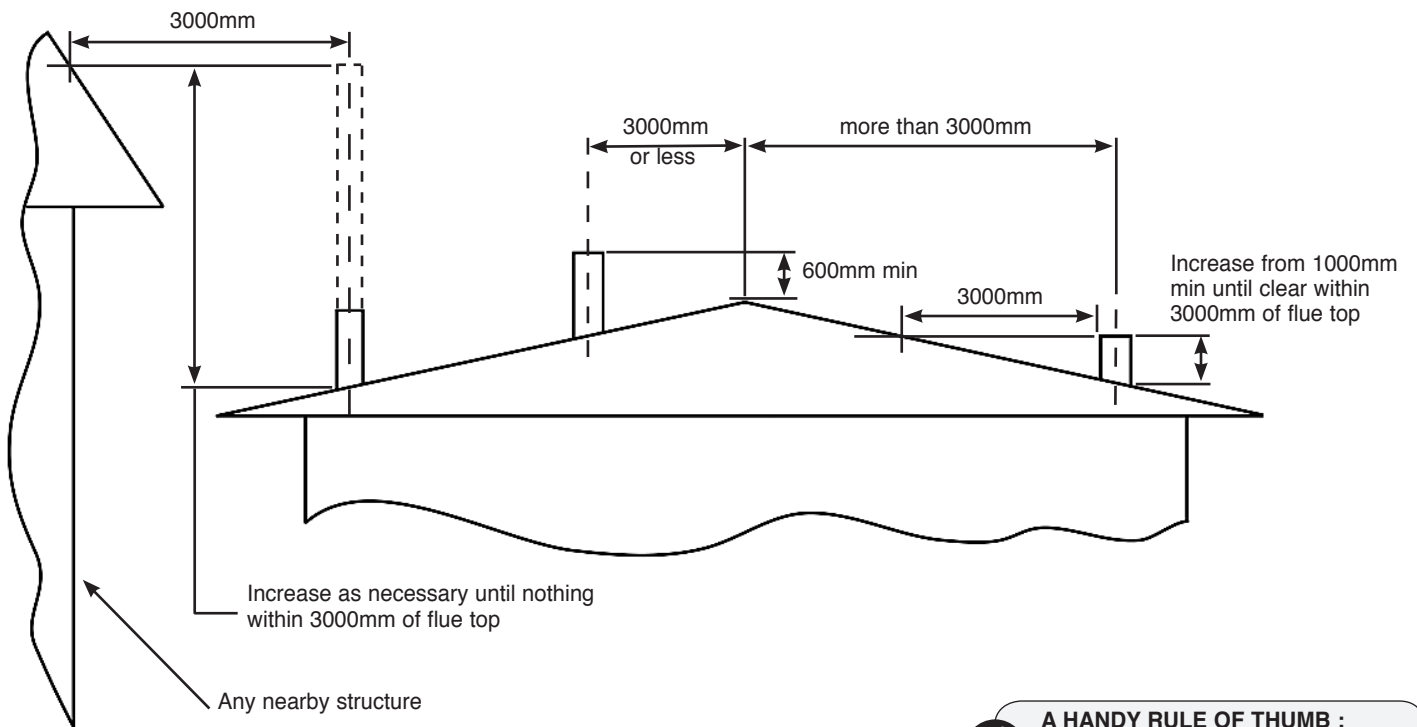
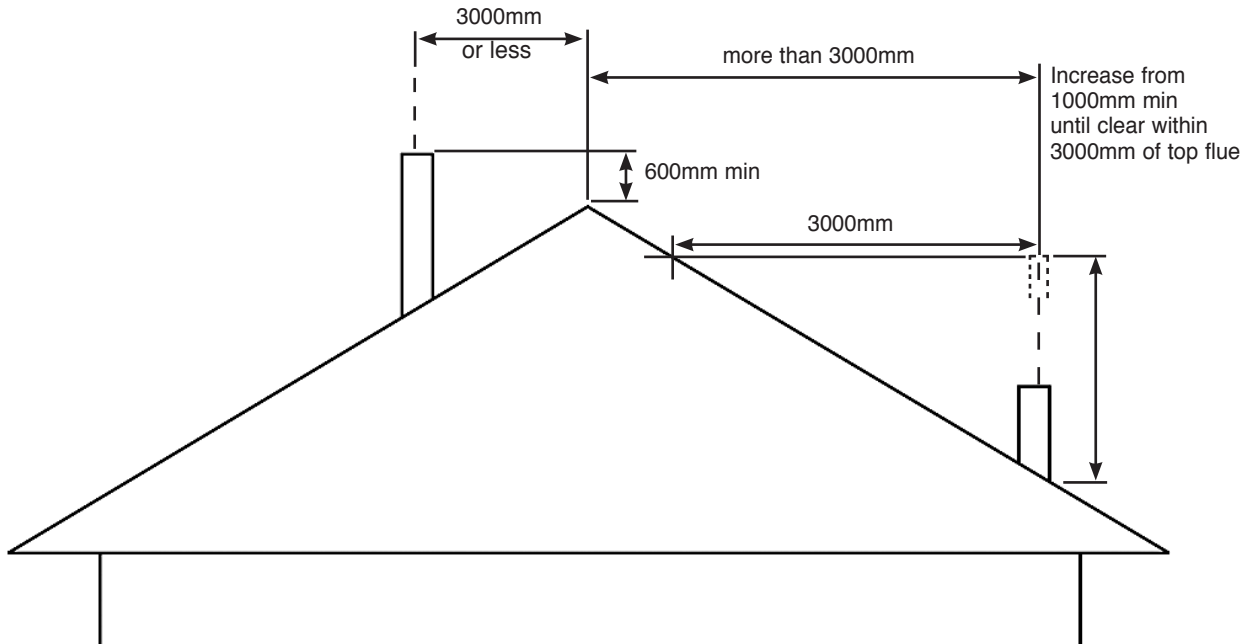

i **A HANDY RULE OF THUMB :**
Terminate all flues a minimum of 600mm above the highest ridgeline of the donor building.

Flues - Technical Appendix

3. Flues and Chimneys

- 3.1 **WARNING: THE APPLIANCE AND FLUE-SYSTEM SHALL BE INSTALLED IN ACCORDANCE WITH AS/NZS 2918 AND THE APPROPRIATE REQUIREMENTS OF THE RELEVANT BUILDING CODE OR CODES.**
- 3.2 **WARNING: APPLIANCES INSTALLED IN ACCORDANCE WITH THIS STANDARD SHALL COMPLY WITH THE REQUIREMENTS OF AS/NZS 4013 WHERE REQUIRED BY THE REGULATORY AUTHORITY, I.E. THE APPLIANCE SHALL BE IDENTIFIABLE BY A COMPLIANCE PLATE WITH THE MARKING 'TESTED TO AS/NZS 4013'.**
- 3.3 **ANY MODIFICATION OF THE APPLIANCE THAT HAS NOT BEEN APPROVED IN WRITING BY THE TESTING AUTHORITY IS CONSIDERED TO BE IN BREACH OF THE APPROVAL GRANTED FOR COMPLIANCE WITH AS/NZS 4013.**
- 3.4 **CAUTION: MIXING OF APPLIANCE OR FLUE-SYSTEM COMPONENTS FROM DIFFERENT SOURCES OR MODIFYING THE DIMENSIONAL SPECIFICATION OF COMPONENTS MAY RESULT IN HAZARDOUS CONDITIONS. WHERE SUCH ACTION IS CONSIDERED, THE MANUFACTURER SHOULD BE CONSULTED IN THE FIRST INSTANCE.**
- 3.5 The flue or chimney system must be in good condition.
It must be inspected by a competent person and passed for use with the appliance before installation.

Products of combustion entering the room can cause serious health risks.

- 3.6 You must check the following:

- The construction of masonry chimneys, flue block chimneys and connecting flue pipe system must meet the requirements of the Building Regulations and the rules in force.
- A flexible flue liner system must be certified for use with solid fuel systems and installed to Building Regulations and the manufacturer's instructions. The flue liner must be replaced when an appliance is replaced unless proven to be recently installed and in good condition.
- If it is necessary to fit a register plate it must conform to the Building Regulations and the rules in force.
- Ensure the connecting flue pipe is kept a suitable distance from any heat sensitive material and does not form part of the supporting structure of the building.
- Make provision to remove the appliance without the need to dismantle the chimney.
- Any existing flue must be confirmed as suitable for the new intended use as defined in the Building Regulations and the rules in force.
- The flue or chimney systems must be inspected and swept to confirm the system is structurally sound and free from obstructions.
- If the appliance is believed to have previously served an open fire the chimney must be swept a second time within a month of regular use after installation to clear any soot falls that may have occurred due to difference in combustion levels.
- The flue exit from the building must comply with local building control rules.
- Do not connect or share the flue or chimney system with another heating appliance.

- 3.7 Do not connect to systems containing large voids.

- 3.8 You must provide suitable access to enable the collection and removal of debris.

- 3.9 You must sweep and inspect the flue when the appliance is installed. Note: the design of this appliance allows the chimney to be swept through the appliance.

The following must be adhered to:

AS/NZS 2918:2001:4.9.1

- a) The flue pipe shall extend not less than 4.6m above the top floor protector.
- b) The minimum height of the flue system within 3m distance from the highest point of the roof shall be 600mm above that point.
- c) The minimum height of a flue system further than 3m from the highest point of the roof shall be "a minimum" 1000mm above roof penetration.
- d) No part of any building lies in or above a circular area described by a horizontal radius of 3m about the flue system exit.

Ventilation - Technical Appendix

i **A HANDY RULE OF THUMB :**
Terminate all flues a minimum of 600mm above the highest ridgeline of the donor building.

N.B. in extreme wind areas it may be necessary to consult your local agent for further technical assistance.

— If flue is concealed in a chase, allow for air vents (2 x 80mm diam. or equivalent) at the highest possible point on the chimney chase or alternatively, allow a min 25mm air space between the casing cover spigot and the outer casing.

4. Ventilation

Also see Essential Information for requirement.

- 4.1 Increase air supply provisions where a room contains multiple appliances. Internal air pressure balance can be critical.
- 4.2 If vents open into adjoining rooms or spaces there must be an air vent of at least the same size direct to the outside.
- 4.3 For REPLACEMENT AIR site the vents where cold draughts is unlikely to cause discomfort. This can be avoided by placing the vents near or close to the appliance and located as close to floor level as possible.
- 4.4 Additional ventilation is required. This must be provided using a permanently open air vent, of the size listed, which is positioned so that it is not liable to be blocked both inside and outside the building.

i **Allowances MUST be made for air replacement vents to be located near the fireplace to aid combustion.**
A minimum of one pair of air vents is recommended or one large vent.
Allowance is to be made for a minimum of 2 inlet ducts from outside to internal vent location.
Note: DO NOT USE FIREPLACE CAVITY VENTILATION AS A METHOD OF AIR REPLACEMENT.

Ventilation Options

OPTION 1 (Into a sealed chimney chase)

- (a) Replacement air for combustion and cooling requirements
- (b) Optional warm air ducts

Key

A = Inlet air ducts from outside (Replacement air for combustion and cooling of heat cell).

Replacement air x 2 vents providing a minimum of 200cm² cross sectional area each. These vents need to be positioned as near to the fireplace as possible and at or near floor level.

B = Hebel Heat Cell cool/warm air inlet from donor room

Air vents x 2 into Hebel Heat cell – same sizing as for A

C = Warm air ducts from Hebel heat cell
Stovax Warm Air ducting kit

D = Warm air duct outlets to donor room
Stovax Warm Air ducting kit

E = Rockwool seal between flue and Hebel Heat cell top

F = Flue termination cowl

G = Additional cooling air inlet for chase (expelled via vents at top or oversized casing cover)

H = Combustion air to fire drawn from the room air

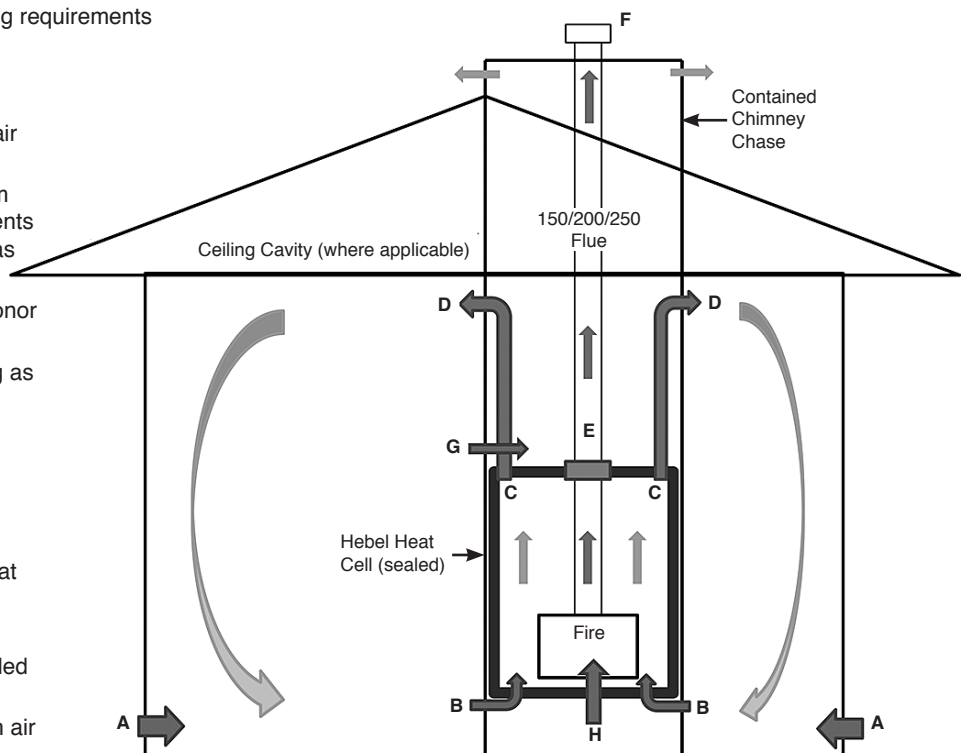

Technical Appendix - Ventilation

OPTION 2 (Into a chase open to the ceiling cavity)

- (a) Replacement air for combustion and cooling requirements
- (b) Warm air vents and ceiling cavity venting

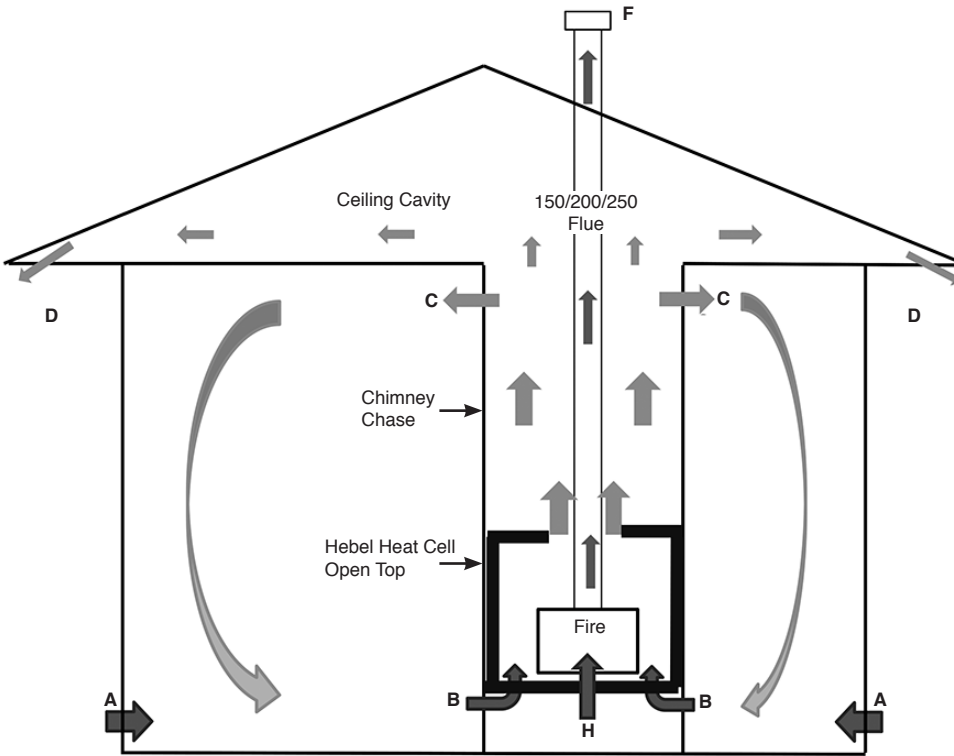

Key

- A** = Inlet air ducts from outside (Replacement air for combustion and cooling of heat cell). Replacement air vents providing a minimum of 200cm² cross sectional area. These vents need to be positioned as near to the fire as possible and at or near floor level.
- B** = Hebel Heat Cell cool/warm air inlet from donor room.
- Air vents x 2 into Hebel Heat cell – same sizing as for A.
- C** = Warm air ducts from Hebel heat cell. Warm Air vents to room – min 200cm²
- D** = Warm air duct outlets to donor room. Ceiling cavity venting through roof structure.
- E** = Rockwool seal between flue and Hebel Heat cell top.
- F** = Flue termination cowl.
- G** = Additional cooling air inlet for chase (expelled via vents at top or oversized casing cover).
- H** = Combustion air to fire drawn from the room air.

Air Ventilation For Fireplaces On Internal Walls/Chases

The following two schematic drawings are alternative details for providing air ventilation into a home, where it is not possible to provide ventilation ducts through walls or floors (concrete) without significant construction and/or cost;

- (a) Introduction of external air into a Chimney chase via air vents from a soffit (or similar).
- (b) Replacement air for combustion for an installed fireplace into a room via air vents from a soffit (or similar). Suggested minimum air vent size is 100mm x 100mm or approximate equivalent. Larger is better, but is dependent on design and aesthetic considerations. Air vent covers should be bird and vermin proofed. It is recommended to site both types of air vents, as low down and as close as possible to floor level. DO NOT locate these incoming vents into the chase or room, so that they vent above the fireplace opening.

Introduction of external air into a CHIMNEY CHASE via soffit ducts (or similar)

Introduction of REPLACEMENT AIR into a Fireplace room via soffit ducts (or similar)

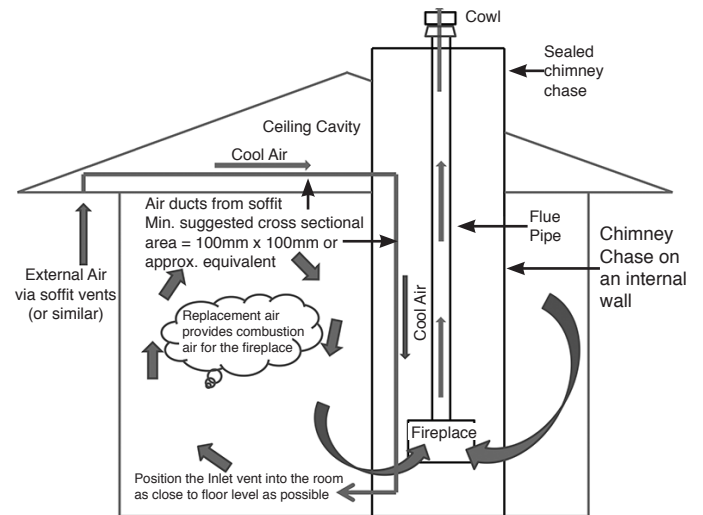
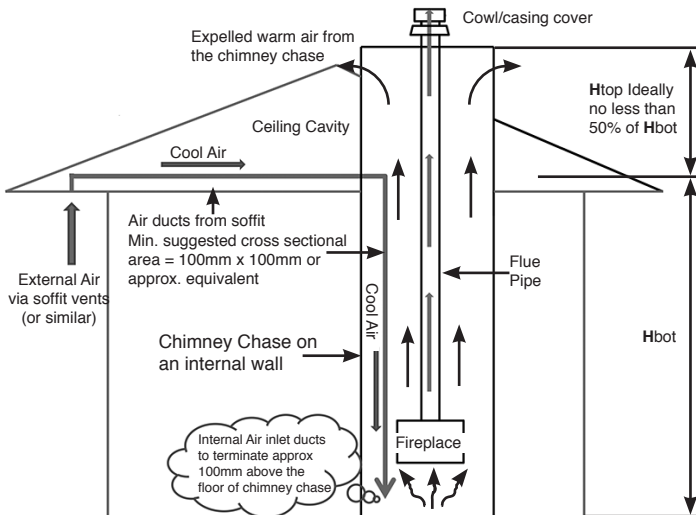

Technical Appendix

5. Minimum Dimensions - Floor Protector

- 5.1 The appliance must have a heat resistant floor protector which is at least 12mm thick with the minimum dimensions as shown in the diagram on Page 6.
- As this appliance can be installed in an elevated setting a 12mm floor protector is required to be extended a minimum of dimension C from the door opening, see page 6.
- 5.2 The building must have a suitable load-bearing capacity for the floor protector and appliance. Consult a structural engineer for advice before proceeding.
- 5.3 When fitting into an existing floor protector check that the floor protector complies with current construction regulations and is at least the minimum sizes shown.
- 5.4 If there is no existing fireplace or chimney it is possible to construct a suitable heat resistant housing and floor protector setting. The flue must be installed in accordance with all local and national regulations and current rules in force.



NOTE: A hearth depth of 470mm is required for a Studio 2 fitted with a Verve frame

Basic Spare Parts

RVST-1 Studio 1

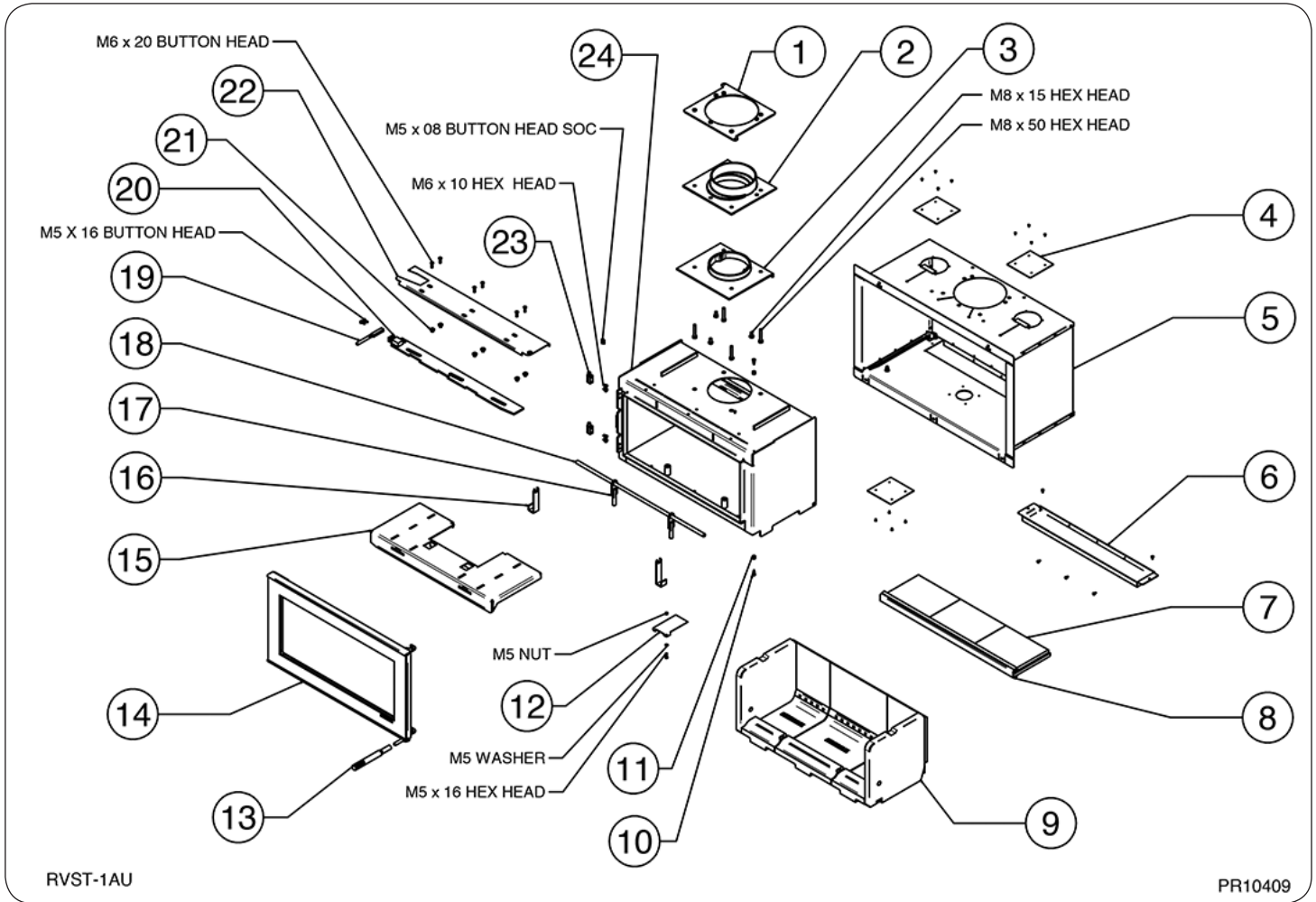

Ref. No.	Description	Part No.
1	FLUE CLAMP PLATE ASSEMBLY	RVS-MEC10126
2	TOP COLLAR	RVS-CA7512
3	LOWER COLLAR	RVS-CA7767
4	CONVECTOR AIR COVER	RVS-ME7376
5	OUTER BODY ASSEMBLY	RVS-MEC10157
6	FAN BLANKING INFILL	RVS-RA501902
7	BRICK BAFFLE	RVS-CE7469
8	BRICK BAFFLE SUPPORT	RVS-RA503511
9	WOOD BRICK ASSEMBLY SKAMOL	RVS-MEC10270
10	CATCH ROLLER PIN	RVS-ME601278
11	CATCH ROLLER	RVS-ME601277
12	DATA PLATE MOUNT	RVS-RA502194
13	TOOL HANDLE	RVS-ME600213
14	DOOR ASSEMBLY	RVS-MEC10150
15	TOP BAFFLE ASSEMBLY	RVS-MEC10164
16	LOG GUARD END SUPPORT	RVS-RA503351
17	LOG GUARD SUPPORT ASSEMBLY	RVS-MEC8500
18	LOG GUARD	RVS-ME601390
19	AIRWASH HANDLE	RVS-ME601346
20	AIRWASH SLIDER	RVS-MEC10331
21	AIRWASH SPACER	RVS-ME601354
22	AIRWASH SLIDER COVER	RVS-RA503507
23	HINGE BLOCK ASSEMBLY	RVS-MEC8373
24	INNER BOX ASSEMBLY	RVS-MEC10330

Due to continual technical improvements please check with your Stovax retailer for the most up to date parts lists.

Basic Spare Parts

RVST-2 Studio 2

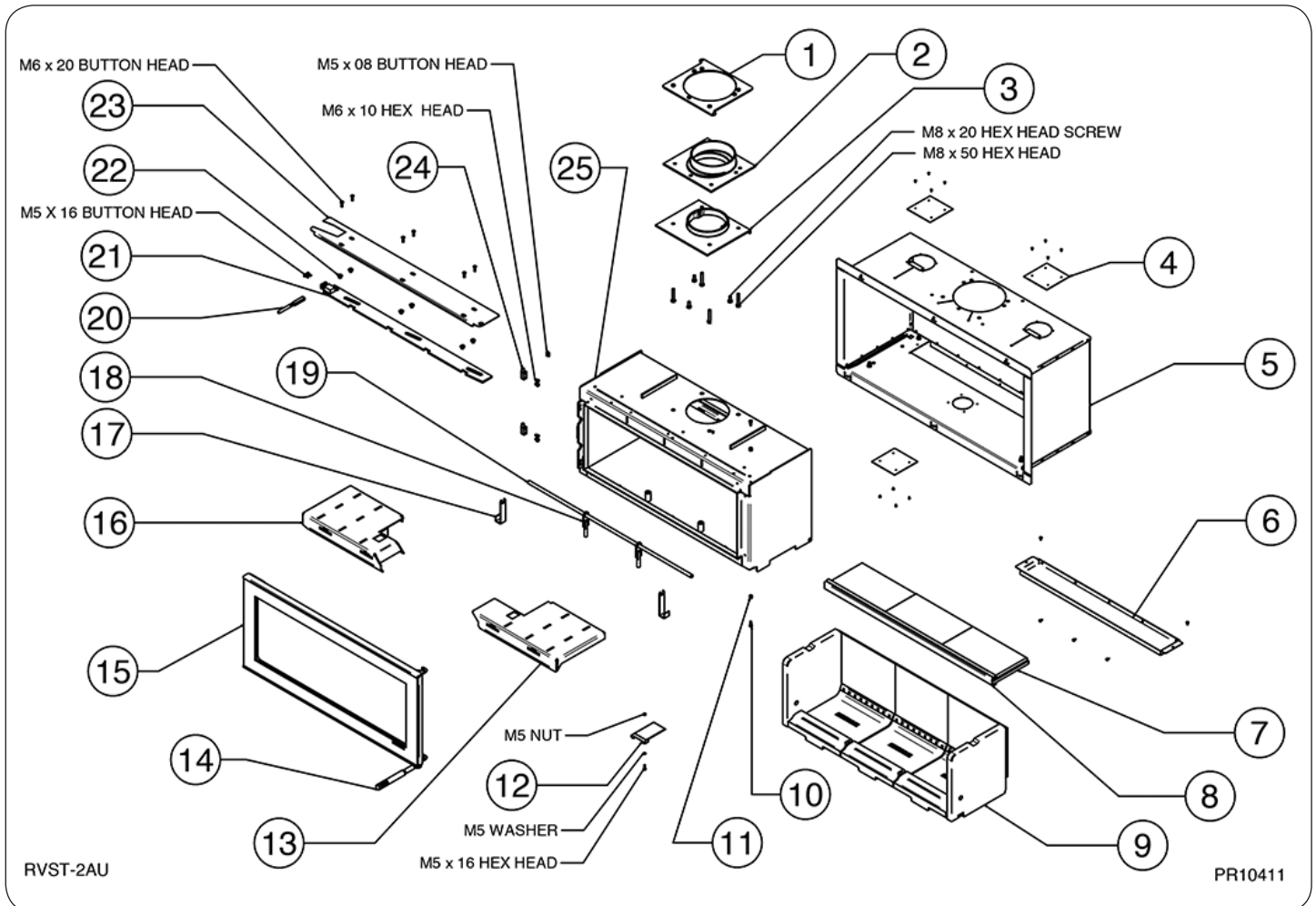

Ref. No.	Description	Part No.
1	FLUE CLAMP PLATE ASSEMBLY	RVS-MEC10126
2	TOP COLLAR	RVS-CA7512
3	LOWER COLLAR	RVS-CA7767
4	CONVECTOR AIR COVER	RVS-ME7376
5	OUTER BOX ASSEMBLY	RVS-MEC10099
6	FAN INFILL	RVS-RA502008
7	BAFFLE BRICK	RVS-CE7468
8	BRICK BAFFLE SUPPORT	RVS-RA503452
9	BRICK ASSEMBLY	RVS-MEC10271
10	CATCH ROLLER	RVS-ME601278
11	CATCH ROLLER PIN	RVS-ME601277
12	DATA PLATE MOUNT	RVS-RA502194
13	TOP BAFFLE RHS	RVS-MEC10101
14	TOOL HANDLE	RVS-ME600213
15	DOOR ASSEMBLY	RVS-MEC10103
16	TOP BAFFLE LHS	RVS-MEC10102
17	LOG GUARD END SUPPORT	RVS-RA503351
18	LOG GUARD SUPPORT ASSEMBLY	RVS-MEC8500
19	LOG GUARD	RVS-ME601353
20	AIRWASH HANDLE	RVS-ME601346
21	AIRWASH SLIDER	RVS-MEC10336
22	AIRWASH SPACER	RVS-ME601354
23	AIRWASH SLIDER COVER	RVS-RA503451
24	HINGE BLOCK ASSEMBLY	RVS-MEC8373
25	INNER BOX ASSEMBLY	RVS-MEC10335

Due to continual technical improvements please check with your Stovax retailer for the most up to date parts lists.

Basic Spare Parts

RVST-3 Studio 3

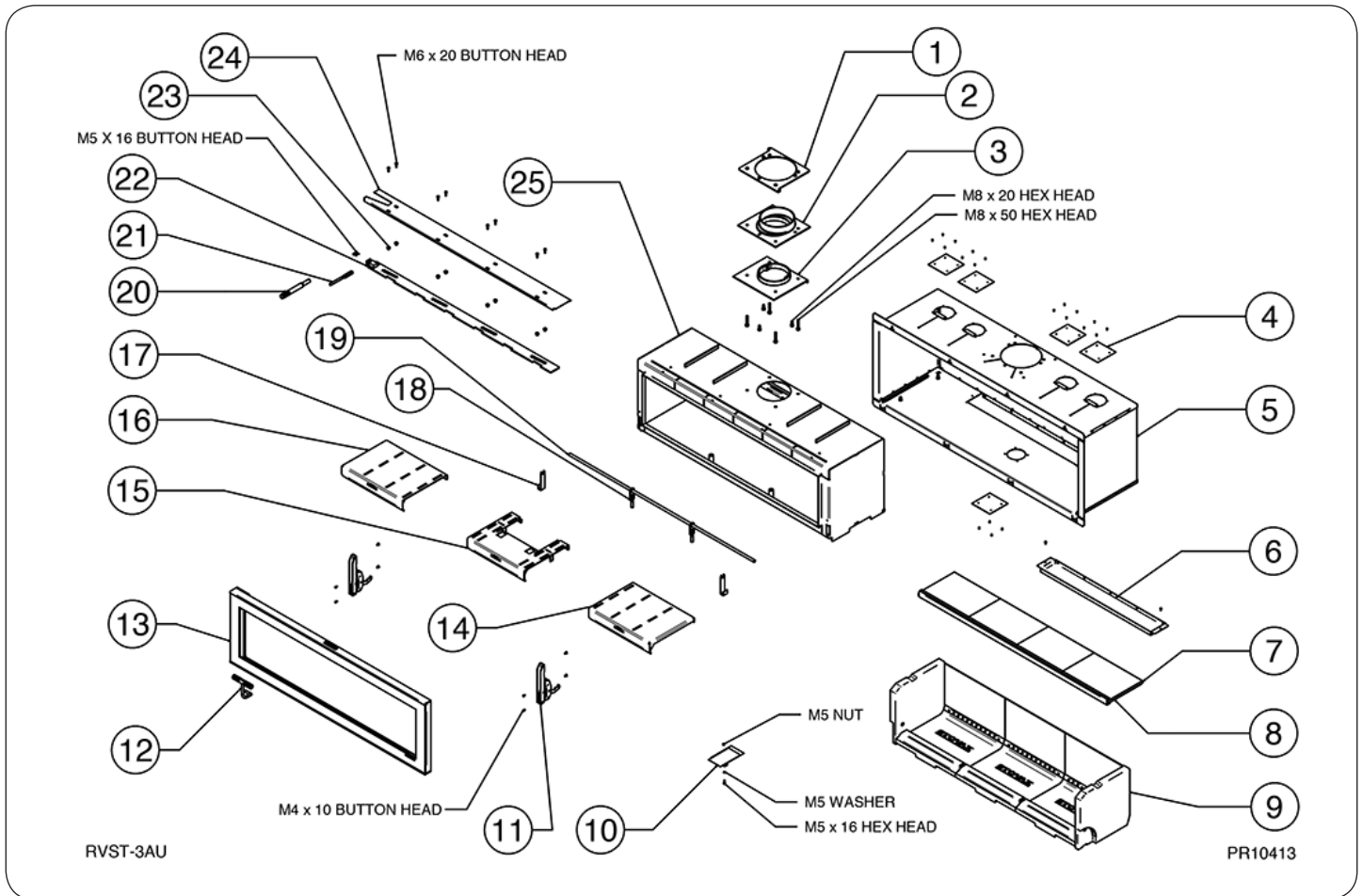

Ref. No.	Description	Part No.
1	FLUE CLAMP PLATE ASSEMBLY	RVS-MEC10126
2	TOP COLLAR	RVS-CA7512
3	LOWER COLLAR	RVS-CA7767
4	CONVECTOR AIR COVER	RVS-ME7376
5	OUTER BOX ASSEMBLY	RVS-MEC10192
6	FAN INFILL	RVS-RA502008
7	BRICK BAFFLE	RVS-CE7520
8	BAFFLE SUPPORT	RVS-RA503531
9	BRICK ASSEMBLY	RVS-MEC10272
10	DATA PLATE MOUNT	RVS-RA502190
11	HINGE	RVS-MEC9266
12	DOOR TOOL	RVS-MEC8552
13	DOOR ASSEMBLY	RVS-MEC8300
14	BAFFLE RHS	RVS-MEC10206
15	CENTRE BAFFLE	RVS-MEC10204
16	BAFFLE LHUS	RVS-MEC10205
17	LOG GUARD END SUPPORT	RVS-RA503538
18	LOG GUARD SUPPORT ASSEMBLY	RVS-MEC8500
19	LOG GUARD	RVS-ME601402
20	TOOL HANDLE	RVS-ME600213
21	AIRWASH HANDLE	RVS-ME601452
22	AIRWASH SLIDER	RVS-MEC10326
23	AIRWASH SPACER	RVS-ME601354
24	AIRWASH SLIDER COVER	RVS-RA503530
25	INNER BOX ASSEMBLY	RVS-MEC10325

Due to continual technical improvements please check with your Stovax retailer for the most up to date parts lists.

Basic Spare Parts

DOOR ASSEMBLY - STUDIO 1 & 2

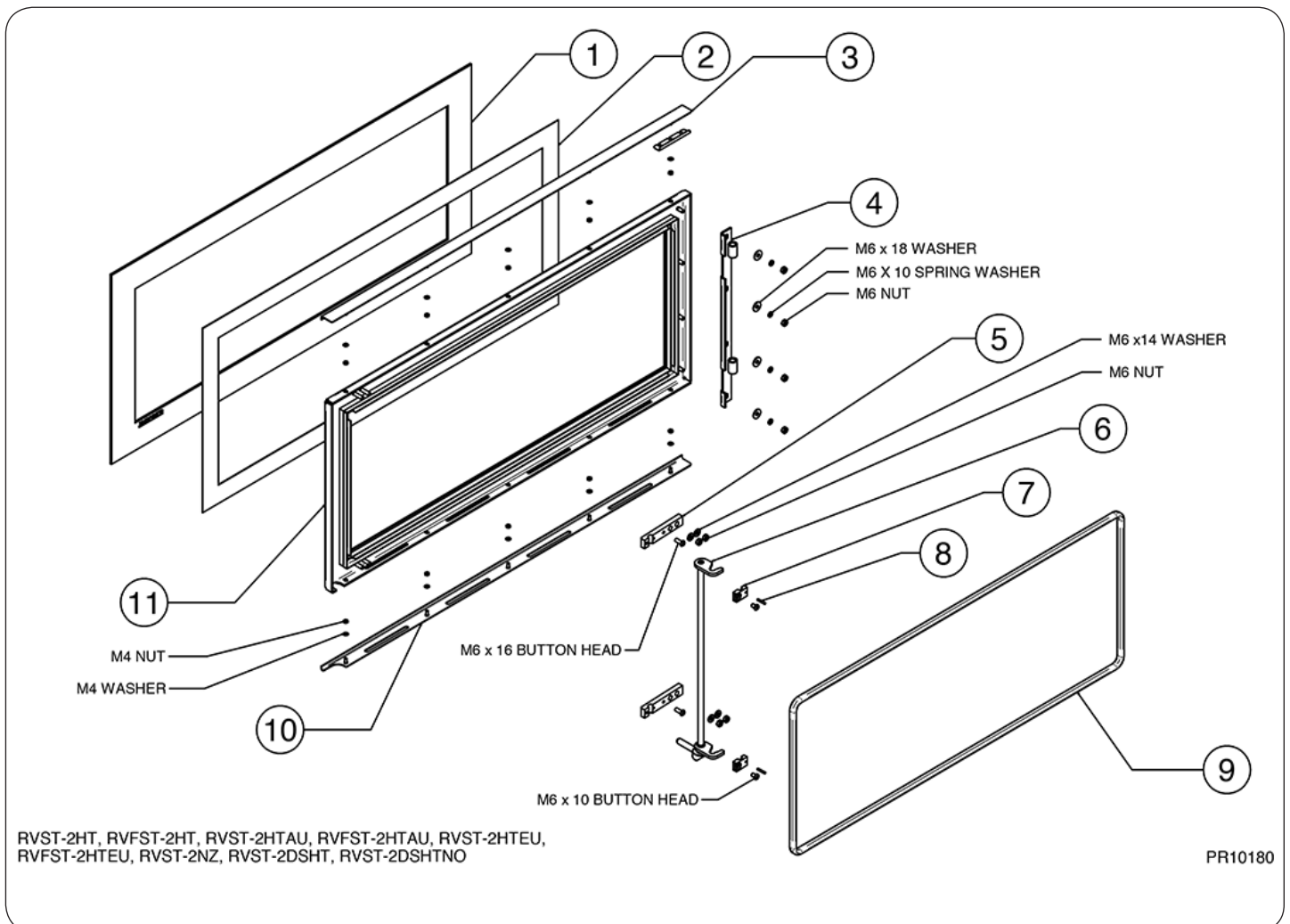

STUDIO 1 DOOR ASSEMBLY

Ref. No.	Description	Part No.
1	STUDIO 1 DOOR GLASS	MEC8940
2	GLASS ROPE	4197 / 5705
3	TOP GLASS CLAMP ASSEMBLY	RVS-MEC8285
4	HINGE ASSEMBLY	RVS-MEC10172
5	LOWER CATCH BLOCK	RVS-ME601266
6	DOOR CATCH ASSEMBLY	RVS-MEC10167
7	UPPER CATCH BLOCK	RVS-ME601261
8	SPIROL PIN Ø3 X 18LG	YM-F00004
9	DOOR ROPE	4200F / 5700
10	DOOR FRAME ASSEMBLY	RVS-MEC10166
11	BOTTOM GLASS CLAMP	RVS-MEC10168

STUDIO 2 DOOR ASSEMBLY

Ref. No.	Description	Part No.
1	STUDIO 2 DOOR GLASS	MEC8941
2	GLASS ROPE	4197 / 5705
3	TOP GLASS CLAMP ASSEMBLY	RVS-MEC8239
4	HINGE ASSEMBLY	RVS-MEC10009
5	LOWER CATCH BLOCK	RVS-ME601266
6	DOOR CATCH ASSEMBLY	RVS-MEC10010
7	UPPER CATCH BLOCK	RVS-ME601261
8	SPIROL PIN Ø3 X 18LG	YM-F00004
9	DOOR ROPE	4200F / 5702
10	DOOR FRAME ASSEMBLY	RVS-MEC10008
11	BOTTOM GLASS CLAMP	RVS-MEC10104

Due to continual technical improvements please check with your Stovax retailer for the most up to date parts lists.

Basic Spare Parts

Due to continual technical improvements please check with your Stovax retailer for the most up to date parts lists.

STUDIO 1 BRICK ASSEMBLY

Ref. No.	Description	Part No.
1	BASE CENTRE BRICK	RVS-CE7632
2	BASE SIDE BRICK	RVS-CE7631
3	REAR SIDE BRICK	RVS-CE7634
4	REAR CENTRE BRICK	RVS-CE7635
5	SIDE BRICK RIGHT HAND SIDE	RVS-CE8085
6	SIDE BRICK LEFT HAND SIDE	RVS-CE8084

STUDIO 2 BRICK ASSEMBLY

Ref. No.	Description	Part No.
1	BASE BRICK	RVS-CE7613
2	BACK BRICK SIDE	RVS-CE7624
3	BACK BRICK CENTRE	RVS-CE7615
4	SIDE BRICK RHS	RVS-CE8078
5	SIDE BRICK LHS	RVS-CE8079

PR9418 - 1

Basic Spare Parts

Due to continual technical improvements please check with your Stovax retailer for the most up to date parts lists.

DOOR ASSEMBLY - STUDIO 3

The diagram shows an exploded view of the Studio 3 door assembly. Components are numbered 1 through 8. Callouts include: M6 x 15 STUD, M6 NUT, M6 X 10 SPRING WASHER, M4 x 10 WELD STUD, M4 NUT, and M4 PENNY WASHER.

Ref. No.	Description	Part No.
1	DOOR ROPE	5704
2	DOOR FRAME ASSEMBLY	RVS-MEC8302
3	BOTTOM GLASS CLAMP ASSEMBLY	RVS-MEC8360
4	GLASS ROPE	4197 / 5705
5	STUDIO 3 DOOR GLASS	MEC8942
6	HANDLE SUPPORT	RA503616
7	TOP GLASS CLAMP	RVS-MEC8359
8	DOOR OPENING BLOCK	RVS-MEC8547

RVS-3, RVFS-3 PR10356

STUDIO 3 BRICK ASSEMBLY

The diagram shows an exploded view of the Studio 3 brick assembly. Components are numbered 1 through 5. The bricks have 'STOVAX' branding on the front face.

Ref. No.	Description	Part No.
1	BASE BRICK	RVS-CE7626
2	REAR SIDE BRICK	RVS-CE7628
3	REAR CENTRE BRICK	RVS-CE7627
4	SIDE BRICK LEFT HAND SIDE	CE8087
5	SIDE BRICK RIGHT HAND SIDE	CE8088

RVS-3, RVFS-3 PR10357

FPA Warranty Statement

Limited Warranty

FPI Fireplace Products International Ltd. ("the distributor") through its wholly owned subsidiary, Fireplace Products Australia Pty Ltd and sold under the Stovax brand of fireplace products, extends this Limited Warranty to the original purchaser of this appliance provided the product remains in the original place of installation.

The items covered by this limited warranty and the period of such coverage is set forth in the table below.

Some conditions apply (see below).

The policy is not transferable, amendable or negotiable under any circumstances.

Wood Products	
Components Covered	Warranty
Welded Firebox Steel	2 years
All Stainless Steel Components, Smoke Deflectors, Heat Shields etc.	1 year
Door handle and latch assembly, all hardware	1 year
Glass Thermal Breakage Only	1 year
Steel Faceplates, Accessory Housings	1 year
All Plating	1 year
Ash Drawer, Heatshields, Pedestal	1 year
All Baffles-Steel, Ceramic, Vermiculite	1 year
All castings, firebox, surrounds, doors, panels etc.	1 year
All Electrical, Fans, wiring, switches etc.	1 year
Glass - Crazing	1 year
Firebricks	Nil

After the original warranty coverage for any of the parts above have expired, any repair and/or replacement parts purchased by the consumer from FPI or through an accredited distributor or dealer will carry a ninety (90) day warranty (valid only with an original copy of the tax invoice). No labor coverage is included with any repair and/or replacement part.

Replacement parts are limited to one per warranty term.

Exclusions

This Limited Warranty does not extend to paint, rust or corrosion of any kind due to a lack of maintenance or improper venting, combustion air provision, corrosive chemicals (i.e. chlorine, salt, air, etc.), firebrick (rear, sides or bottom), door or glass gasket, or any other additional factory fitted gasket.

Malfunction, damage or performance based issues as a result of environmental conditions, location, chemical damages, downdrafts, installation error, installation by an unqualified installer, incorrect chimney components (including but not limited to cap size or type), operator error, abuse, misuse, use of improper fuels (such as unseasoned timber, mill-ends, construction timber or debris, off-cuts, treated or painted timber, tea tree, metal or foil, plastics, garbage, solvents, cardboard, coal or coal products, oil based products, waxed cartons, compressed pre-manufactured logs), accidents, lack of regular maintenance and upkeep, acts of God, weather related problems from hurricanes, tornados, earthquakes, floods, lightning strikes/bolts or acts of terrorism or war, which result in malfunction of the appliance are not covered under the terms of this Limited Warranty.

FPI has no obligation to enhance or modify any unit once manufactured (i.e. as products evolve, field modifications or upgrades will not be performed on existing appliances).

Any unit showing signs of neglect or misuse will not be covered under the terms of this warranty policy and may void this warranty. This includes units with rusted or corroded fireboxes which have not been reported as rusted or corroded within three (3) months of installation/purchase. Any alteration to the unit which causes sooting or carboning that results in damage to the exterior fascia or over firing that can cause component or firebox/heat exchanger failure will not be covered by this warranty.

Units which show evidence of being operated while damaged, or with problems known to the purchaser and causing further damages will void this warranty.

Units where the serial no. has been altered, deleted, removed or made illegible will void this warranty.

FPA Warranty Statement

Minor movement, expansion and contraction of the steel is normal and is not covered under the terms of this warranty.

Freight damages for products or parts are not covered under the terms of the warranty.

Porcelain/Enamel: Absolute perfection is neither guaranteed nor commercially possible. Any chips must be reported and inspected by the authorised selling dealer within three (3) days of installation. Any damage of this type not reported after this time period will be subject to rejection and any related warranty will not apply.

Special Finishes: Expect some changes in color as the product "ages" with constant heating and cooling. The manufacturer warranty does not cover tarnishing, changing colors and/or marks (i.e. finger prints, etc.) after the purchase of the product. Damage from the use of abrasive cleaners is not covered by warranty.

Products made or provided by other manufacturers and used in conjunction with the FPI appliance without prior authorisation from FPI may void this warranty.

INCORRECT INSTALLATION IS NOT COVERED BY WARRANTY. A SERVICE OR CALLOUT FEE WILL BE CHARGED IN THESE CIRCUMSTANCES.

Limitations of Liability

1. Exclusion of implied terms

The customer may have the benefit of consumer guarantees under the Australian Consumer Law. To the maximum extent permitted by law, all terms, conditions or warranties that would be implied into this Warranty or in connection with the supply of any goods or services by the supplier under law or statute or custom or international conventions are excluded.

2. Limitation of liability

(a) To the maximum extent permitted by law and subject to clauses 1 and 3, the supplier's total liability arising out of or in connection with its performance or its obligations pursuant to this Warranty, or arising out of or in connection with the supply of specific goods or services (including pursuant to or for breach of this Warranty, under statute, in equity or for tort, including negligent acts or omissions) is limited as follows: (i) the supplier shall have no liability to the customer for any Consequential Loss; (ii) without limiting the effect of clause 2(a)(i), the supplier's total aggregate liability for Loss, however arising, shall not exceed the GST exclusive aggregate price paid by the customer to the supplier for the specific goods or services that gave rise to the Loss in question.

(b) The limitations and exclusions in this sub-clause do not apply to the extent that any Loss is directly attributable to: (i) the personal injury or death caused by the supplier's default, breach of this Warranty or negligence; or (ii) fraud by the supplier.

(c) Each party must take reasonable steps to mitigate any Loss it suffers or incurs.

3. Limitation of liability under Australian Consumer Law Guarantees

(a) To the extent that goods supplied by the supplier are not goods of a kind ordinarily acquired for personal, domestic or household use and the customer is deemed to be a consumer for the purposes of section 64A of the Australian Consumer Law, the customer agrees that the supplier's liability for a failure to comply with a consumer guarantee that the customer may have a benefit under the Australian Consumer Law (other than a guarantee under sections 51 (title), 52 (undisturbed possession) and 53 (undisclosed securities)), is limited to, at the option of the supplier, one or more of the following: (i) replacement of the goods or the supply of equivalent goods; (ii) the repair of the goods; (iii) the payment of the cost of replacing the goods or of acquiring equivalent goods; or (iv) equivalent goods; or (v) the payment of the cost of having the goods repaired.

(b) To the extent that services supplied by the supplier are services other than services of a kind ordinarily acquired for personal, domestic or household use or consumption, the supplier's liability for failure to comply with a consumer guarantee that the customer may have the benefit of is limited to, at the option of the supplier: (i) the supply of the services again; or (ii) the payment of the cost of having the services supplied again.

4. Subject to Change

This Limited Warranty is given at the time of sale and purchase of the relevant fireplace product. The terms of this Limited Warranty may be amended from time to time by FPI in accordance with changes to business practices, consumer laws or other legal requirements. The rights and protections granted under the Limited Warranty are those in force in relation to a fireplace product at the time and in the place of sale of that product, and only those terms will be applicable in respect of that product.

5. Severability

Any term of this Limited Warranty that is invalid or unenforceable in any jurisdiction is to be read down for the purposes of that jurisdiction, if possible, so as to be valid and enforceable, and is otherwise capable of being severed to the extent of the invalidity or unenforceability, without affecting the remaining provisions of this Limited Warranty or affecting the validity or enforceability of that provision in any other jurisdiction.

6. Definitions

For purposes of clauses 1, 2 and 3:

(a) Consequential Loss means loss of expected savings, loss of use, loss of opportunity, loss of profit, loss of revenue, increased financing costs, loss arising from delay, or any consequential, special or indirect loss or damage, whether or not the possibility or potential extent of the loss or damage was known or foreseeable, and whether arising from a claim under indemnity, contract, tort (including negligence), statute or otherwise.

(b) Loss means any expense, cost or damage of any kind and includes Consequential Loss and a fine or penalty imposed by a statutory or other authority.

Service Records

1ST SERVICE

Date of Service:.....
Next Service Due:.....
Signed:.....
Dealer's Stamp/SFAIT Registration Number/ AHHA
License Number

3RD SERVICE

Date of Service:.....
Next Service Due:.....
Signed:.....
Dealer's Stamp/SFAIT Registration Number/ AHHA
License Number

5TH SERVICE

Date of Service:.....
Next Service Due:.....
Signed:.....
Dealer's Stamp/SFAIT Registration Number/ AHHA
License Number

7TH SERVICE

Date of Service:.....
Next Service Due:.....
Signed:.....
Dealer's Stamp/SFAIT Registration Number/ AHHA
License Number

9TH SERVICE

Date of Service:.....
Next Service Due:.....
Signed:.....
Dealer's Stamp/SFAIT Registration Number/ AHHA
License Number

2ND SERVICE

Date of Service:.....
Next Service Due:.....
Signed:.....
Dealer's Stamp/SFAIT Registration Number/ AHHA
License Number

4TH SERVICE

Date of Service:.....
Next Service Due:.....
Signed:.....
Dealer's Stamp/SFAIT Registration Number/ AHHA
License Number

6TH SERVICE

Date of Service:.....
Next Service Due:.....
Signed:.....
Dealer's Stamp/SFAIT Registration Number/ AHHA
License Number

8TH SERVICE

Date of Service:.....
Next Service Due:.....
Signed:.....
Dealer's Stamp/SFAIT Registration Number/ AHHA
License Number

10TH SERVICE

Date of Service:.....
Next Service Due:.....
Signed:.....
Dealer's Stamp/SFAIT Registration Number/ AHHA
License Number

Distributed by:

Fireplace Products Australia Pty Ltd
1-3 Conquest Way
Hallam, VIC, 3803
AUSTRALIA
Ph: +61397997299
Fax: +61397997822
Web: www.stovax.com.au
Email: stovax-sales@regency-fire.com.au

Adapted from English Issue 15 of PM274



PM1589